

# GEMME

✂ 10 mm - 3/8" spessore . thickness . épaisseur . stärke . толщина ✂ 8,5 mm - 5/16" spessore . thickness . épaisseur . stärke . толщина



100x100 - 40"x40" 50x100 - 20"x40" 80x180 - 32"x72" 180x20 - 72"x8"  
40x80 - 16"x32" 60x120 - 24"x48" 60x60 - 24"x24" 30x60 - 12"x24"

## Pezzi Speciali . Trims . Pièces Spéciales . Formstücke . Специальные изделия



Battiscopa  
6,5x60 . 2 9/16"x24" rett ► C5

- 1060525 Black Mirror
- 1060535 Fossena
- 1060533 Daino
- 1060537 Saturnia
- 1060531 Colorado
- 1060529 B. Sabbia
- 1060527 B. Cenere

Battiscopa  
6,5x60 . 2 9/16"x24" lux-rett ► C6

- 1060524 Black Mirror
- 1060534 Fossena
- 1060532 Daino
- 1060536 Saturnia
- 1060530 Colorado
- 1060528 B. Sabbia
- 1060526 B. Cenere

✂ 10 mm - 3/8" spessore . thickness . épaisseur . stärke . толщина



Battiscopa  
6,5x100 . 2 9/16"x40" lux-rett ► C8

- 1060516 Black Mirror
- 1060522 Fossena
- 1060521 Daino
- 1060523 Saturnia
- 1060520 Colorado
- 1060518 B. Sabbia
- 1060517 B. Cenere

✂ 8,5 mm - 5/16" spessore . thickness . épaisseur . stärke . толщина

	BOX			PALLET		
	PZ	SQM	KGS	BOXES	SQM	KGS
80x180 . 32"x72" lux-rett	1	1,44	29,30	36	51,84	1.100
180x20 . 72"x8" lux-rett	4	1,44	29,30	36	51,84	1.100
80x20 . 32"x8" lux-rett	8	1,28	26,00	42	53,76	1.140
100x100 . 40"x40" lux-rett	1	1,00	20,65	42	42,00	900
50x100 . 20"x40" lux-rett	2	1,00	20,65	42	42,00	900
40x80 . 16"x32" lux-rett/ rett	3	0,96	21,60	28	26,88	625
60x120 . 24"x48" lux-rett/ rett	2	1,44	33,50	21	30,24	720
	2	1,44	33,50	30	43,20	1.021
60x60 . 24"x24" lux-rett	3	1,08	25,20	32	34,56	830
	3	1,08	25,20	40	43,20	1.024
60x60 . 24"x24" rett	3	1,08	25,00	32	34,56	820
	3	1,08	25,00	40	51,84	1.016
30x60 . 12"x24" lux-rett	6	1,08	25,00	40	43,20	1.020
30x60 . 12"x24" rett	6	1,08	24,80	40	43,20	1.010
Battiscopa 6,5x60 . 2 9/16"x24" lux-rett/ rett	12	7,20 ml	11,00			
Battiscopa 6,5x100 . 2 9/16"x40" lux-rett	6	6,00 ml	7,50			

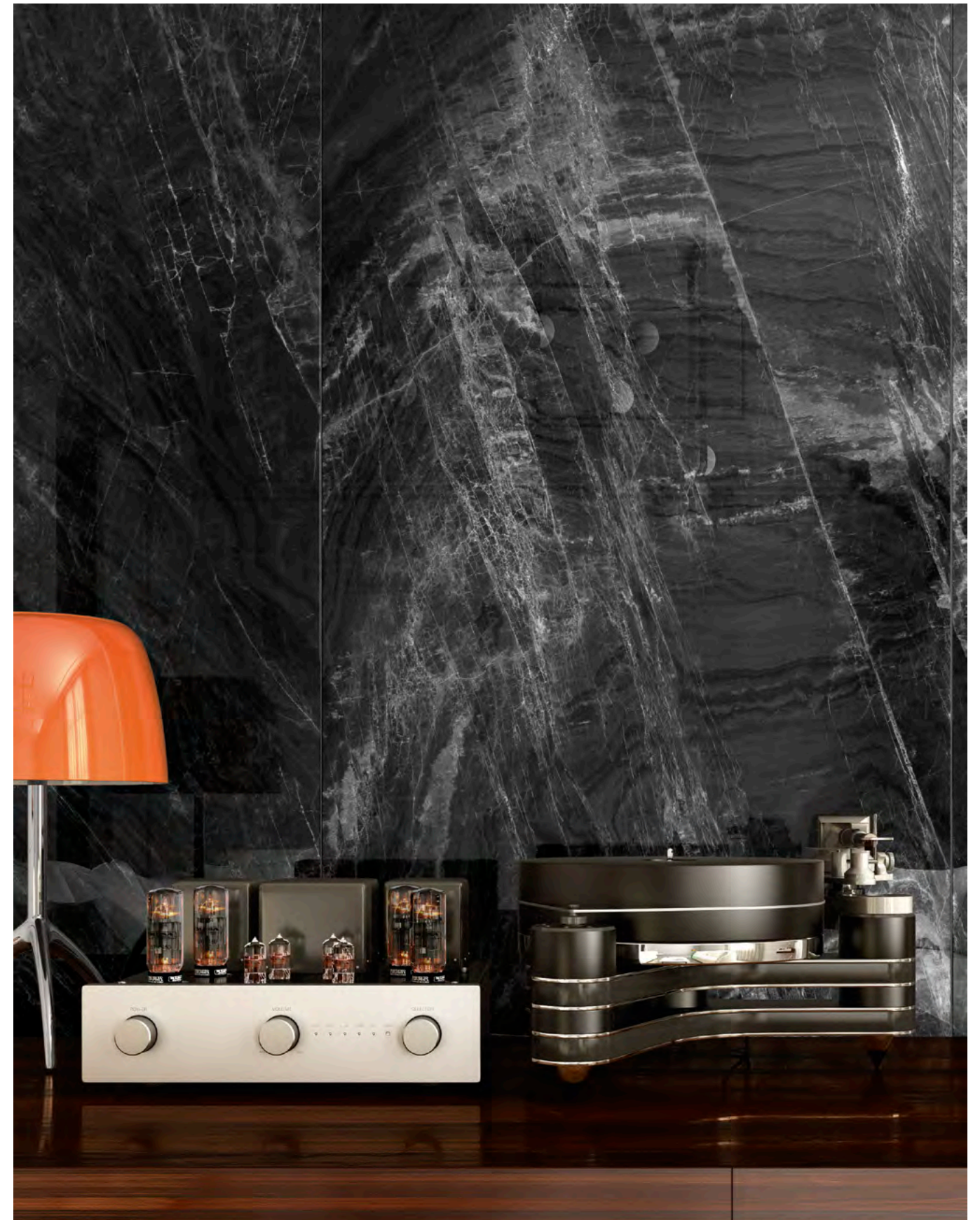

Black Mirror 80x180 . 32"x72" lux-rett



New Oak 20x120 . 8"x48" rett



New Fir



New Maple



New Ash



New Birch



New Oak

# NEWPORT 2.0

20x120 8"x48"  
30x120 12"x48"



**NEWPORT 2.0**



134

135

New Maple 20x120 . 8"x48" rett

New Ash 20x120 . 8"x48" rett / 30x120 . 12"x48" rett / Mosaico Spinetta New Ash 31x31 . 12<sup>3</sup>/<sub>16</sub>"x12<sup>3</sup>/<sub>16</sub>" rett

# NEWPORT 2.0

10 mm spessore .  $\frac{3}{8}$ " thickness . épaisseur . stärke . толщина

10mm R9 V4 20x120 - 8"x48" . 30x120 - 12"x48"

## Colours

### New Fir



1055833 30x120 . 12"x48" rett ■ A21



1055832 20x120 . 8"x48" rett ■ A23

### New Ash



1055725 30x120 . 12"x48" rett ■ A21



1055720 20x120 . 8"x48" rett ■ A23

### New Maple



1055728 30x120 . 12"x48" rett ■ A21



1055723 20x120 . 8"x48" rett ■ A23

### New Birch

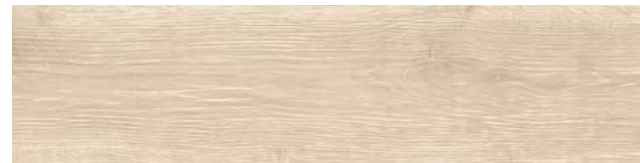

1055726 30x120 . 12"x48" rett ■ A21



1055721 20x120 . 8"x48" rett ■ A23

### New Oak



1055729 30x120 . 12"x48" rett ■ A21



1055724 20x120 . 8"x48" rett ■ A23

## Mosaici . Mosaics . Mosaïques . Mosaiken . Мозаика

### 30x30 - 12"x12" Foglio. Sheet. Feuille. Blatt. Лист



1058308 Mosaico New Fir tessera 5x5 . 2"x2" rett ● B13



1058305 Mosaico New Ash tessera 5x5 . 2"x2" rett ● B13



1058309 Mosaico New Maple tessera 5x5 . 2"x2" rett ● B13

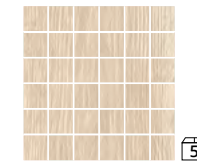

1058306 Mosaico New Birch tessera 5x5 . 2"x2" rett ● B13

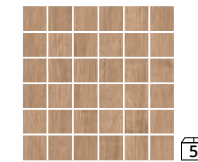

1058310 Mosaico New Oak tessera 5x5 . 2"x2" rett ● B13

### 31x31 - 12 $\frac{3}{16}$ "x12 $\frac{3}{16}$ " Foglio. Sheet. Feuille. Blatt. Лист



1058337 Mosaico Spinetta New Fir 31x31 . 12  $\frac{3}{16}$ "x12  $\frac{3}{16}$ " rett ● B18



1058334 Mosaico Spinetta New Ash 31x31 . 12  $\frac{3}{16}$ "x12  $\frac{3}{16}$ " rett ● B18



1058338 Mosaico Spinetta New Maple 31x31 . 12  $\frac{3}{16}$ "x12  $\frac{3}{16}$ " rett ● B18



1058335 Mosaico Spinetta New Birch 31x31 . 12  $\frac{3}{16}$ "x12  $\frac{3}{16}$ " rett ● B18



1058339 Mosaico Spinetta New Oak 31x31 . 12  $\frac{3}{16}$ "x12  $\frac{3}{16}$ " rett ● B18

## Pezzi Speciali . Trims. Pièces Spéciales. Formstücke. Специальные изделия



Battiscopa 7,5x120 - 3"x48" rett ► C7  
1055791 New Ash  
1055792 New Birch  
1055834 New Fir  
1055794 New Maple  
1055795 New Oak



Gradone Costa Retta 30x120x3,3 - 12"x48"x1  $\frac{5}{16}$ " rett ● B51  
1063171 New Ash  
1063172 New Birch  
1063174 New Fir  
1063175 New Maple  
1060125 New Oak



Gradone Square Assemblato 30x120x3,3 - 12"x48"x1  $\frac{5}{16}$ " rett ● B62  
1055796 New Ash  
1062314 New Birch  
1063178 New Fir  
1063179 New Maple  
1063180 New Oak

	BOX			PALLET		
	PZ	SQM	KGS	BOXES	SQM	KGS
20x120 . 8"x48" rett	4	0,96	20,70	36	34,56	770
30x120 . 12"x48" rett	4	0,96	20,70	48	46,08	1.010
Battiscopa 7,5x120 . 3"x48" rett	6	7,20 ml	12,00			
Gradone Costa Retta 30x120x3,3 . 12"x48"x1 $\frac{5}{16}$ " rett	2		17,00			
Gradone Square Assemblato 30x120x3,3 . 12"x48"x1 $\frac{5}{16}$ " rett	2		18,60			



Beautiful Shade



Golden Sunset



Nordic Land



Natural Feeling



Long Night

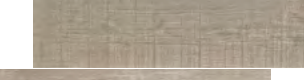
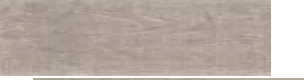

Norway Mix Cold

# NORWAY

Beautiful Shade 20x120 . 8"x48" rett / 30x120 . 12"x48" rett  
 Mosaico Bricks Long Night 20x60 . 8"x24" rett  
 Wall07 White Leaf (comp. 2pz) 120x120 . 48"x48" rett (collezione Showall, pag. 220)

20x120 8"x48"  
 30x120 12"x48"  
 15x90 6"x36"  
 26,5x180 10 1/4"x72"



Golden Sunset 15x90 . 6"x36" rett

Norway Mix Cold 20x120 . 8"x48" rett



142







143

Long Night 20x120 . 8"x48" rett / 30x120 . 12"x48" rett

Natural Feeling 20x120 . 8"x48" rett

# NORWAY

 **10 mm** - 3/8"  
**spessore** . *thickness* . *épaisseur* . *stärke* . *толщина*  **8,5 mm** - 5/16"  
**spessore** . *thickness* . *épaisseur* . *stärke* . *толщина*

       **20x120** - 8"x48" . **30x120** - 12"x48" . **15x90** - 6"x36" . **26,5x180** - 10 1/4"x72"

## Colours

### Beautiful Shade

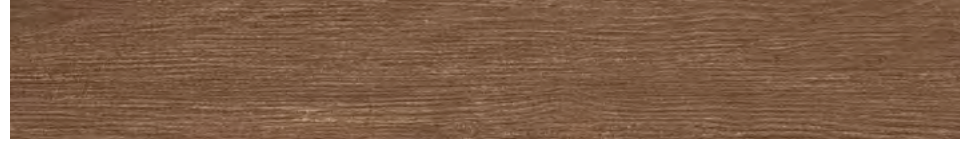

**1059068** Le Plance 26,5x180 . 10 1/4"x72" rett ■ **A41**

 **8,5 mm** - 5/16"  
**spessore**  
*thickness*  
*épaisseur*  
*stärke*  
*толщина*



**1050644** 30x120 . 12"x48" rett ■ **A21**

 **10 mm** - 3/8"  
**spessore**  
*thickness*  
*épaisseur*  
*stärke*  
*толщина*



**1050638** 20x120 . 8"x48" rett ■ **A23**



**1050894** 15x90 . 6"x36" rett ■ **A14**

### Golden Sunset



**1050645** 30x120 . 12"x48" rett ■ **A21**



**1050639** 20x120 . 8"x48" rett ■ **A23**



**1050895** 15x90 . 6"x36" rett ■ **A14**

 **10 mm** - 3/8"  
**spessore**  
*thickness*  
*épaisseur*  
*stärke*  
*толщина*

### Nordic Land



**1059076** Le Plance 26,5x180 . 10 1/4"x72" rett ■ **A41**

 **8,5 mm** - 5/16"  
**spessore**  
*thickness*  
*épaisseur*  
*stärke*  
*толщина*



**1050648** 30x120 . 12"x48" rett ■ **A21**

 **10 mm** - 3/8"  
**spessore**  
*thickness*  
*épaisseur*  
*stärke*  
*толщина*



**1050642** 20x120 . 8"x48" rett ■ **A23**



**1050898** 15x90 . 6"x36" rett ■ **A14**

### Natural Feeling



**1059075** Le Plance 26,5x180 . 10 1/4"x72" rett ■ **A41**

 **8,5 mm** - 5/16"  
**spessore**  
*thickness*  
*épaisseur*  
*stärke*  
*толщина*

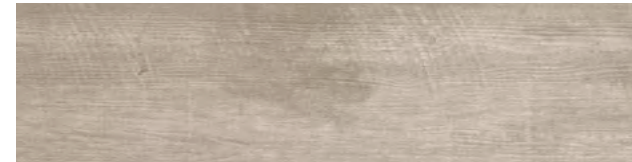

**1050647** 30x120 . 12"x48" rett ■ **A21**



**1050641** 20x120 . 8"x48" rett ■ **A23**



**1050897** 15x90 . 6"x36" rett ■ **A14**

 **10 mm** - 3/8"  
**spessore**  
*thickness*  
*épaisseur*  
*stärke*  
*толщина*



# NORWAY

✂ 10 mm - 3/8" spessore . thickness . épaisseur . stärke . толщина ✂ 8,5 mm - 5/16" spessore . thickness . épaisseur . stärke . толщина

10 mm 8,5 mm R10 V4 20x120 - 8"x48" . 30x120 - 12"x48" . 15x90 - 6"x36" . 26,5x180 - 10 1/4"x72"

## Colours

### Long Night



1050646 30x120 . 12"x48" rett ■ A21



1050640 20x120 . 8"x48" rett ■ A23



1050896 15x90 . 6"x36" rett ■ A14

### Norway Mix Cold



1050643 20x120 . 8"x48" rett ■ A25

✂ 10 mm - 3/8" spessore . thickness . épaisseur . stärke . толщина

## Mosaici . Mosaics . Mosaïques . Mosaiken . Мозаика



1052879 Mosaico Intreccio Cold (Long Night - Natural Feeling) (11,5 pz al mq) ● B29



1052880 Mosaico Intreccio Warm (Beautiful Shade - Golden Sunset) (11,5 pz al mq) ● B29

### 30x30 - 12"x12" Foglio. Sheet. Feuille. Blatt. Лист



1050914 Mosaico Beautiful Shade tessera 5x5 . 2"x2" rett ● B13



1050915 Mosaico Golden Sunset tessera 5x5 . 2"x2" rett ● B13



1050916 Mosaico Long Night tessera 5x5 . 2"x2" rett ● B13



1050917 Mosaico Natural Feeling tessera 5x5 . 2"x2" rett ● B13



1050918 Mosaico Nordic Land tessera 5x5 . 2"x2" rett ● B13

### 20x60 - 8"x24" Foglio. Sheet. Feuille. Blatt. Лист



1052536 Mosaico Bricks Beautiful Shade 20x60 . 8"x24" rett ● B22



1052538 Mosaico Bricks Golden Sunset 20x60 . 8"x24" rett ● B22



1052540 Mosaico Bricks Long Night 20x60 . 8"x24" rett ● B22



1052541 Mosaico Bricks Natural Feeling 20x60 . 8"x24" rett ● B22



1052542 Mosaico Bricks Nordic Land 20x60 . 8"x24" rett ● B22

## Pezzi Speciali . Trims. Pièces Spéciales. Formstücke. Специальные изделия



Battiscopa 7,5x120 . 3"x48" rett ► C7

1050739 Beautiful Shade  
1050740 Golden Sunset  
1050741 Long Night  
1050742 Natural Feeling  
1050893 Nordic Land



Battiscopa 7,5x90 . 3"x36" rett ► C4

1053550 Beautiful Shade  
1053551 Golden Sunset  
1053552 Long Night  
1053553 Natural Feeling  
1053554 Nordic Land



Battiscopa 9x60 . 3 9/16"x24" ► C2

1053079 Beautiful Shade  
1053081 Golden Sunset  
1053082 Long Night  
1053083 Natural Feeling  
1053084 Nordic Land



Gradone Costa Retta 30x120x3,3 - 12"x48"x1 5/16" rett ● B51

1059987 Beautiful Shade  
1063182 Golden Sunset  
1063183 Long Night  
1063184 Natural Feeling  
1063185 Nordic Land



Gradone Square Assemblato 30x120x3,3 - 12"x48"x1 5/16" rett ● B62

1053652 Beautiful Shade  
1053659 Golden Sunset  
1053660 Long Night  
1053675 Natural Feeling  
1053662 Nordic Land

	BOX			PALLET		
	PZ	SQM	KGS	BOXES	SQM	KGS
26,5x180 . 10 1/4"x72" rett	3	1,43	28,50	36	51,48	1.041
20x120 . 8"x48" rett	4	0,96	20,70	36	34,56	770
	4	0,96	20,70	48	46,08	1.010
30x120 . 12"x48" rett	4	1,44	31,00	24	34,56	760
15x90 . 6"x36" rett	9	1,215	26,00	48	58,32	1.264
Battiscopa 7,5x120 . 3"x48" rett	6	7,20 ml	12,00			
Battiscopa 7,5x90 . 3"x36" rett	6	5,40 ml	8,50			
Battiscopa 9x60 . 3 9/16"x24"	15	9,00 ml	15,00			
Gradone Costa Retta 30x120x3,3 . 12"x48"x1 5/16" rett	2		17,00			
Gradone Square Assemblato 30x120x3,3 . 12"x48"x1 5/16" rett	2		18,60			



Noce 30x120 . 12"x48" rett / Wall08 Garden (comp. 2pz) 120x120 . 48"x48" rett (collezione Showall, pag. 220)



Bianco



Miele

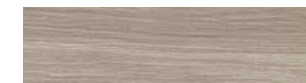

Grigio



Rovere



Noce

# ÀCANTO

20x120 8"x48"  
 30x120 12"x48"  
 26,5x180 10 1/4"x72"



Grigio 30x120 . 12"x48" rett / Wall02 Mayfair Grey 60x120 . 24"x48" (collezione Showall, pag. 220)

Miele 30x120 . 12"x48" rett / Mosaico Bricks Miele 20x60 . 8"x24" rett

# ÀCANTO

 10 mm spessore . thickness . épaisseur . stärke . толщина  8,5 mm spessore . thickness . épaisseur . stärke . толщина

  R10 V3    20x120 - 8"x48" . 30x120 - 12"x48" . 26,5x180 - 10 1/4"x72"

## Colours

### Bianco



1059069 Le Plance 26,5x180 . 10 1/4"x72" rett ■ A41

 8,5 mm spessore . thickness . épaisseur . stärke . толщина

### Miele

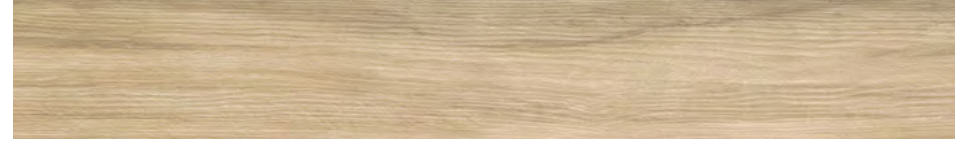

1059074 Le Plance 26,5x180 . 10 1/4"x72" rett ■ A41

 8,5 mm spessore . thickness . épaisseur . stärke . толщина

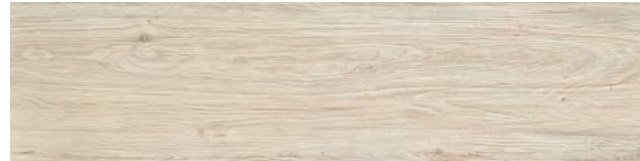

1047706 30x120 . 12"x48" rett ■ A21

 10 mm spessore . thickness . épaisseur . stärke . толщина

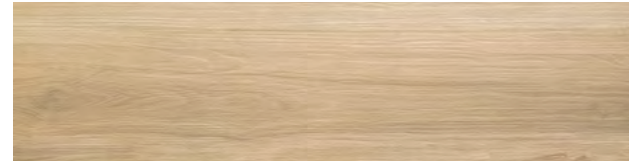

1047708 30x120 . 12"x48" rett ■ A21

 10 mm spessore . thickness . épaisseur . stärke . толщина



1047427 20x120 . 8"x48" rett ■ A23



1047429 20x120 . 8"x48" rett ■ A23

### Grigio



1059073 Le Plance 26,5x180 . 10 1/4"x72" rett ■ A41

 8,5 mm spessore . thickness . épaisseur . stärke . толщина

### Rovere



1047710 30x120 . 12"x48" rett ■ A21

### Noce



1047709 30x120 . 12"x48" rett ■ A21

 10 mm spessore . thickness . épaisseur . stärke . толщина



1047707 30x120 . 12"x48" rett ■ A21

 10 mm spessore . thickness . épaisseur . stärke . толщина



1047431 20x120 . 8"x48" rett ■ A23



1047430 20x120 . 8"x48" rett ■ A23



1047428 20x120 . 8"x48" rett ■ A23

# ÀCANTO

✂ 10 mm spessore - 3/8" thickness . épaisseur . stärke . толщина ✂ 8,5 mm spessore - 5/16" thickness . épaisseur . stärke . толщина

10mm 8,5mm R10 V3 265x180 20x120 - 8"x48" . 30x120 - 12"x48" . 26,5x180 - 10 1/4"x72"

## Mosaici . Mosaics . Mosaïques . Mosaiken . Мозаика

### 30x30 - 12"x12" Foglio. Sheet. Feuille. Blatt. Лист

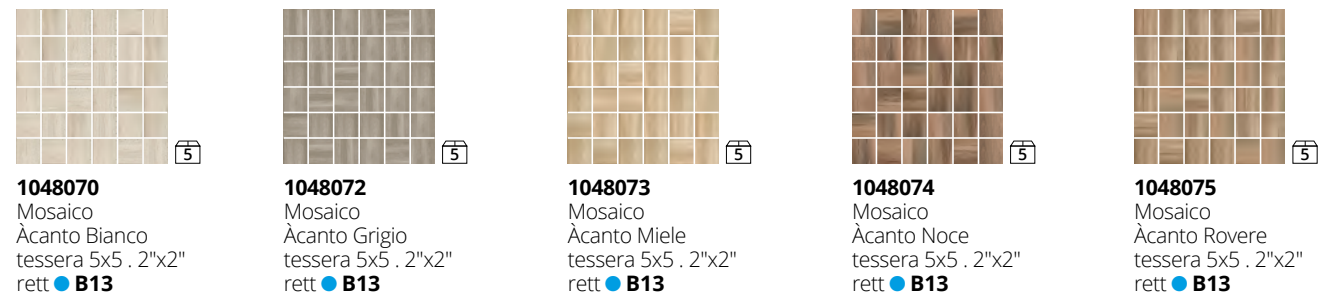

**1048070** Mosaico Àcanto Bianco tessera 5x5 . 2"x2" rett ● **B13**  
**1048072** Mosaico Àcanto Grigio tessera 5x5 . 2"x2" rett ● **B13**  
**1048073** Mosaico Àcanto Miele tessera 5x5 . 2"x2" rett ● **B13**  
**1048074** Mosaico Àcanto Noce tessera 5x5 . 2"x2" rett ● **B13**  
**1048075** Mosaico Àcanto Rovere tessera 5x5 . 2"x2" rett ● **B13**

### 20x60 - 8"x24" Foglio. Sheet. Feuille. Blatt. Лист

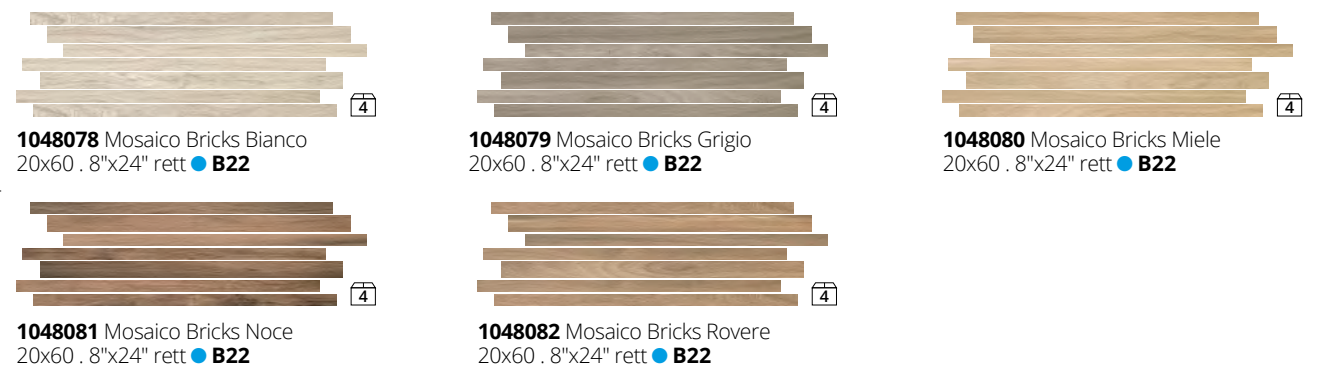

**1048078** Mosaico Bricks Bianco 20x60 . 8"x24" rett ● **B22**  
**1048079** Mosaico Bricks Grigio 20x60 . 8"x24" rett ● **B22**  
**1048080** Mosaico Bricks Miele 20x60 . 8"x24" rett ● **B22**  
**1048081** Mosaico Bricks Noce 20x60 . 8"x24" rett ● **B22**  
**1048082** Mosaico Bricks Rovere 20x60 . 8"x24" rett ● **B22**

### 30x120 - 12"x48" Foglio. Sheet. Feuille. Blatt. Лист



**1048229** Tapparella 2D Bianco listello 7,5x120 . 3"x48" rett ● **B47** 2  
**1048230** Tapparella 2D Grigio listello 7,5x120 . 3"x48" rett ● **B47** 2  
**1048231** Tapparella 2D Miele listello 7,5x120 . 3"x48" rett ● **B47** 2  
**1048232** Tapparella 2D Noce listello 7,5x120 . 3"x48" rett ● **B47** 2  
**1048233** Tapparella 2D Rovere listello 7,5x120 . 3"x48" rett ● **B47** 2

## Pezzi Speciali . Trims. Pièces Spéciales. Formstücke. Специальные изделия



**Battiscopa** 9,8x120 . 3 7/8"x48" rett ► **C7**  
**1048044** Àcanto Bianco  
**1048045** Àcanto Grigio  
**1048046** Àcanto Miele  
**1048047** Àcanto Noce  
**1048048** Àcanto Rovere  
**Gradone Costa Retta** 30x120x3,3 - 12"x48"x1 5/16" rett ● **B51**  
**1063186** Àcanto Bianco  
**1063187** Àcanto Grigio  
**1062395** Àcanto Miele  
**1049155** Àcanto Miele  
**1063188** Àcanto Noce  
**1063191** Àcanto Noce  
**1063189** Àcanto Rovere  
**Gradone Square Assemblato** 30x120x3,3 - 12"x48"x1 5/16" rett ● **B62**  
**1049278** Àcanto Bianco  
**1063190** Àcanto Grigio  
**1049155** Àcanto Miele  
**1063191** Àcanto Noce  
**1063192** Àcanto Rovere

	BOX			PALLET		
	PZ	SQM	KGS	BOXES	SQM	KGS
26,5x180 . 10 1/4"x72" rett	3	1,43	28,50	36	51,48	1.041
20x120 . 8"x48" rett	4	0,96	20,70	36	34,56	770
	4	0,96	20,70	48	46,08	1.010
30x120 . 12"x48" rett	4	1,44	31,00	24	34,56	760
<b>Battiscopa</b> 9,8x120 . 3 7/8"x48" rett	6	7,20 ml	15,50			
<b>Gradone Costa Retta</b> 30x120x3,3 . 12"x48"x1 5/16" rett	2		17,00			
<b>Gradone Square Assemblato</b> 30x120x3,3 . 12"x48"x1 5/16" rett	2		18,60			



Le Plance Natural Feeling 26,5x180 . 10 1/4"x72" rett

-  Bianco
-  Miele
-  Grigio
-  Beautiful Shade
-  Nordic Land
-  Natural Feeling

26,5x180 10 1/4"x72"

# LE PLANCE





Le Plance Grigio 26,5x180 . 10 1/4"x72" rett



Le Plance Miele 26,5x180 . 10 1/4"x72" rett

# LE PLANCE

8,5 mm - 5/16"  
 spessore . thickness . épaisseur . stärke . толщина

8,5mm R10 V3 V4 26,5x180 - 10 1/4"x72"

## Colours

### Bianco



1059069 Le Plance Bianco 26,5x180 . 10 1/4"x72" rett ■ A41

### Miele



1059074 Le Plance Miele 26,5x180 . 10 1/4"x72" rett ■ A41

### Grigio

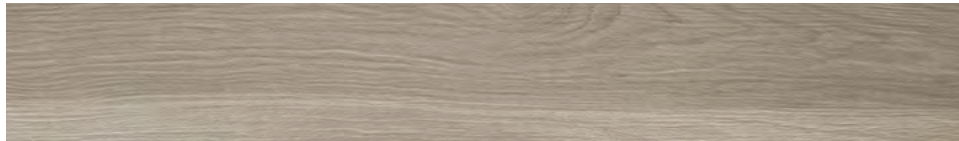

1059073 Le Plance Grigio 26,5x180 . 10 1/4"x72" rett ■ A41

### Beautiful Shade

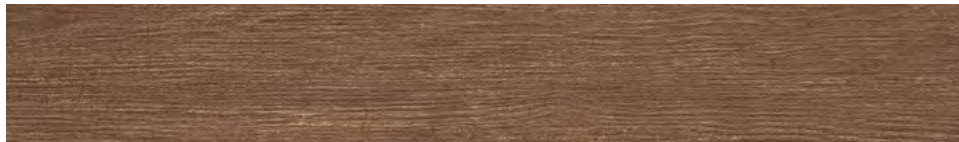

1059068 Le Plance Beautiful Shade 26,5x180 . 10 1/4"x72" rett ■ A41

### Nordic Land



1059076 Le Plance Nordic Land 26,5x180 . 10 1/4"x72" rett ■ A41

### Natural Feeling



1059075 Le Plance Natural Feeling 26,5x180 . 10 1/4"x72" rett ■ A41

	BOX			PALLET		
	PZ	SQM	KGS	BOXES	SQM	KGS
26,5x180 . 10 1/4"x72" rett	3	1,43	28,50	36	51,48	1.041



Le Plance Bianco 26,5x180 . 10 1/4"x72" rett / Wall14 Forest (comp. 2 pz) 120x120 . 48"x48" (collezione Showall, pag. 220)





# URBAN

Mud 18x118 . 7 1/16"x46 7/16" / Battiscopa Mud 9x118 . 3 9/16"x46 7/16"

18x118 7 1/16"x46 7/16"

# URBAN

10 mm spessore . thickness . épaisseur . stärke . толщина

10mm R10 V3 18x118 - 7 1/16"x46 7/16"

## Colours

### Dark



1043907 18x118 . 7 1/16"x46 7/16" ■ A13

### Mud



1043909 18x118 . 7 1/16"x46 7/16" ■ A13

### Ecru



1043908 18x118 . 7 1/16"x46 7/16" ■ A13

### Sand



1043910 18x118 . 7 1/16"x46 7/16" ■ A13

Mosaici . Mosaics . Mosaïques . Mosaiken . Мозаика

30,4x30,4 - 12"x12" Foglio. Sheet. Feuille. Blatt. Лист

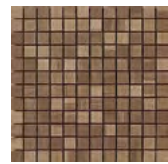

1043912 Mosaico Urban Dark tessera 2,3x2,3 . 7/8"x7/8" ● B19

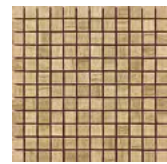

1043913 Mosaico Urban Ecru tessera 2,3x2,3 . 7/8"x7/8" ● B19

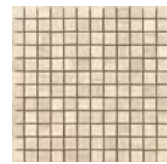

1043915 Mosaico Urban Sand tessera 2,3x2,3 . 7/8"x7/8" ● B19

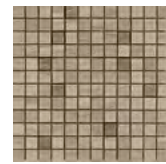

1043914 Mosaico Urban Mud tessera 2,3x2,3 . 7/8"x7/8" ● B19

Pezzi Speciali . Trims . Pièces Spéciales . Formstücke . Специальные изделия



Battiscopa 9x118 . 3 9/16"x46 7/16" ► C7  
1043919 Urban Dark  
1043921 Urban Ecru  
1043922 Urban Mud  
1043923 Urban Sand



Gradone Costa Retta (comp. 2 pz) 36x118x3,3 . 14 3/16"x46 7/16"x1 5/16" ● B50  
1058882 Urban Dark  
1058883 Urban Ecru  
1058884 Urban Mud  
1058886 Urban Sand



Gradone Square Assemblato (comp. 2 pz) 36x118x3,3 . 14 3/16"x46 7/16"x1 5/16" ● B61  
1043925 Urban Dark  
1043927 Urban Ecru  
1043929 Urban Mud  
1043930 Urban Sand

	BOX			PALLET		
	PZ	SQM	KGS	BOXES	SQM	KGS
18x118 . 7 1/16"x46 7/16"	5	1,06	21,50	36	38,16	790
Battiscopa 9,8x118 . 3 9/16"x46 7/16"	6	7,08 ml	14,50			
Gradone Costa Retta 36x118x3,3 . 14 3/16"x46 7/16"x1 5/16"	comp 2		24,00			
Gradone Square Assemblato 36x118x3,3 . 14 3/16"x46 7/16"x1 5/16"	comp 2		25,00			

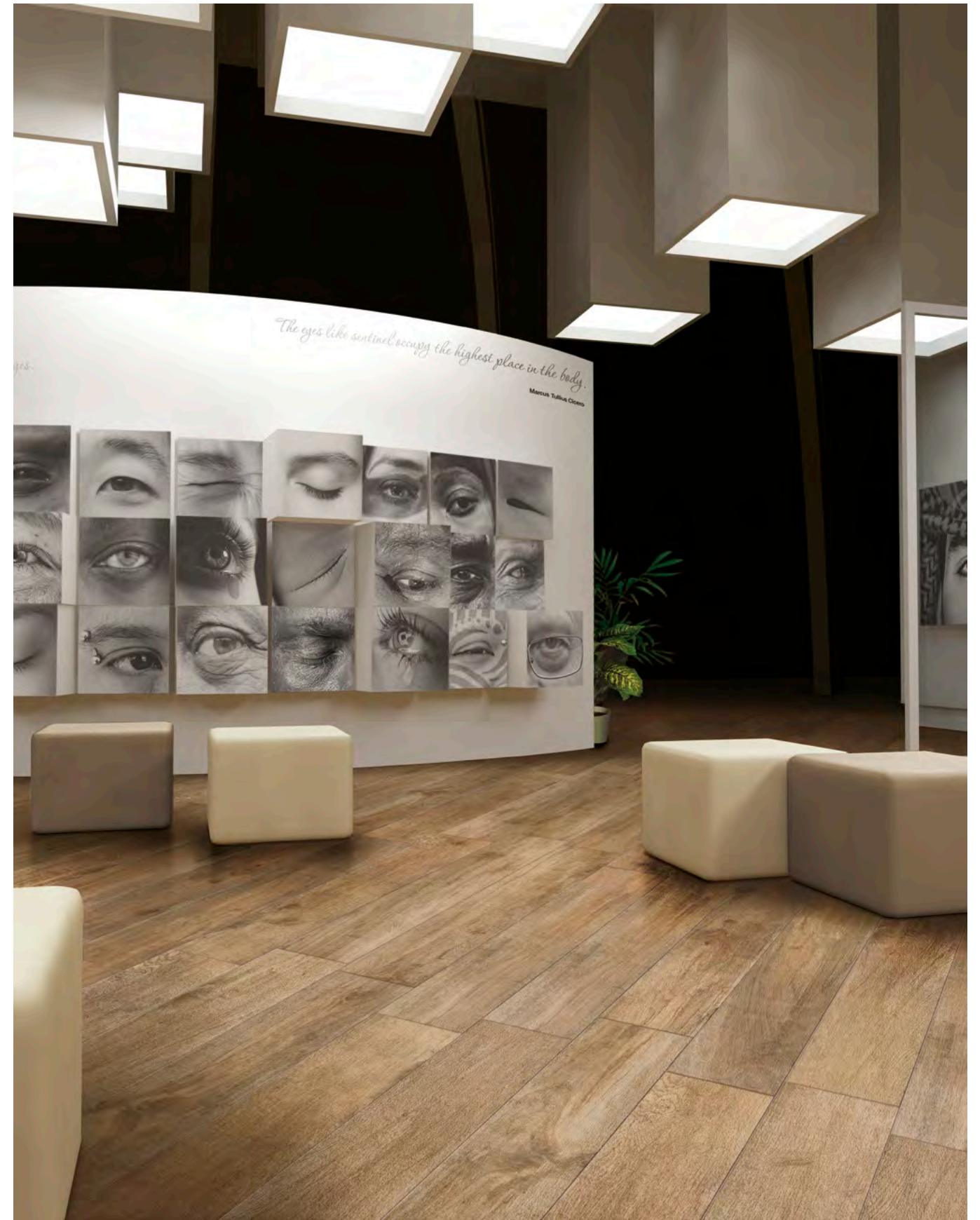

Ecru 18x118 . 7 1/16"x46 7/16"



Carbon 18x118 . 7 1/16"x46 7/16"



Ash



Burned

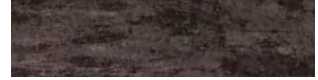

Carbon

# CHARWOOD



18x118 7 1/16"x46 7/16"  
6,5x40 2 9/16"x16"

# CHARWOOD

10 mm spessore . thickness . épaisseur . stärke . толщина

10mm R10 V4 18x118 - 7 1/16"x46 7/16" . 6,5x40 - 2 9/16"x16"

## Colours

### Ash

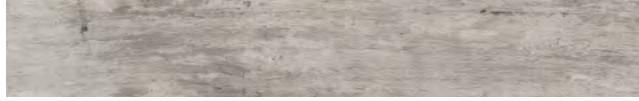

1058434 18x118 . 7 1/16"x46 7/16" ■ A13



1058441 6,5x40 . 2 9/16"x16" ■ A16

### Burned

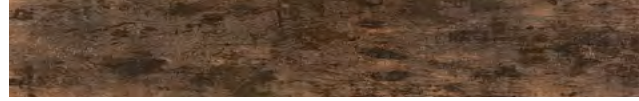

1058437 18x118 . 7 1/16"x46 7/16" ■ A13



1058443 6,5x40 . 2 9/16"x16" ■ A16

### Carbon



1058438 18x118 . 7 1/16"x46 7/16" ■ A13



1058445 6,5x40 . 2 9/16"x16" ■ A16

## Mosaici . Mosaics . Mosaïques . Mosaiken . Мозаика

### 30x30 - 12"x12" Foglio. Sheet. Feuille. Blatt. Лист

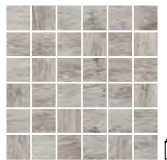

1059029 Mosaico Ash tessera 5x5 . 2"x2" ● B13



1059030 Mosaico Burned tessera 5x5 . 2"x2" ● B13

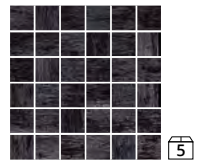

1059031 Mosaico Carbon tessera 5x5 . 2"x2" ● B13

### 31x31 - 12 3/16"x12 3/16" Foglio. Sheet. Feuille. Blatt. Лист



1059032 Mosaico Spinetta Ash 31x31 . 12 3/16"x12 3/16" ● B18



1059033 Mosaico Spinetta Burned 31x31 . 12 3/16"x12 3/16" ● B18



1059034 Mosaico Spinetta Carbon 31x31 . 12 3/16"x12 3/16" ● B18

## Pezzi Speciali . Trims . Pièces Spéciales . Formstücke . Специальные изделия



Battiscopa 9x118 - 3 9/16"x46 7/16" ► C7  
1059035 Ash  
1059036 Burned  
1059037 Carbon



Gradone Costa Retta (comp. 2 pz) 36x118x3,3 - 14 3/16"x46 7/16"x1 5/16" ● B50  
1059038 Ash  
1059039 Burned  
1059040 Carbon



Gradone Square Assemblato (comp. 2 pz) 36x118x3,3 - 14 3/16"x46 7/16"x1 5/16" ● B61  
1059041 Ash  
1059042 Burned  
1059043 Carbon

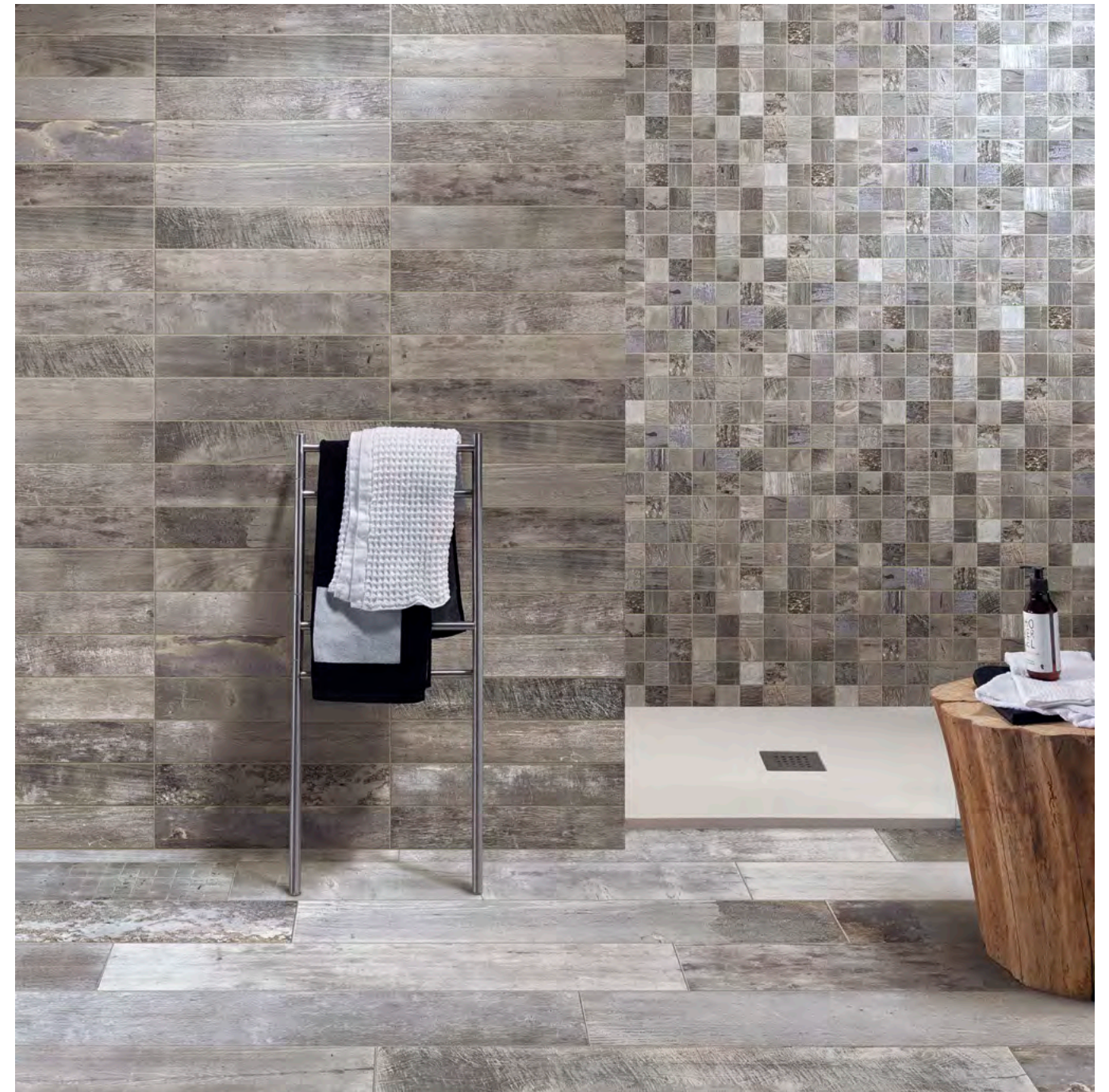

Ash 6,5x40 . 2 9/16"x16" / 18x118 . 7 1/16"x46 7/16" / Mosaico Ash 5x5 . 2"x2"

	BOX			PALLET		
	PZ	SQM	KGS	BOXES	SQM	KGS
18x118 . 7 1/16"x46 7/16"	5	1,06	21,50	36	38,16	790
6,5x40 . 2 9/16"x16"	32	0,83	17,80	48	39,84	871
Battiscopa 9,8x118 . 3 9/16"x46 7/16"	6	7,08 ml	14,50			
Gradone Costa Retta 36x118x3,3 . 14 3/16"x46 7/16"x1 5/16"	comp 2		24,00			
Gradone Square Assemblato 36x118x3,3 . 14 3/16"x46 7/16"x1 5/16"	comp 2		25,00			



Gold 18x118 . 7 1/16"x46 7/16" / Battiscopa 9x118 . 3 9/16"x46 7/16"



White



Black



Brown

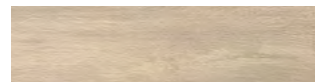

Gold

# TAHOE

18x118 7 1/16"x46 7/16"



172

Brown 18x118 . 7 1/6"x46 7/16" / Black 18x118 . 7 1/6"x46 7/16" / Battiscopa Black 9x118 . 3 9/16"x46 7/16"



173

White 18x118 . 7 1/6"x46 7/16"

# TAHOE

10 mm spessore . thickness . épaisseur . stärke . толщина

10mm R10 V3 18x118 - 7 1/6"x46 7/16"

## Colours

### White



1055719 18x118 . 7 1/6"x46 7/16" ■ A13

### Black



1055715 18x118 . 7 1/6"x46 7/16" ■ A13

### Brown



1055716 18x118 . 7 1/6"x46 7/16" ■ A13

### Gold



1055717 18x118 . 7 1/6"x46 7/16" ■ A13

Mosaici . Mosaics . Mosaiques . Mosaiken . Мозаика

30x30 - 12"x12" Foglio. Sheet. Feuille. Blatt. Лист



1055805 Mosaico White tessera 5x5 . 2"x2" ● B13



1055801 Mosaico Black tessera 5x5 . 2"x2" ● B13



1055802 Mosaico Brown tessera 5x5 . 2"x2" ● B13



1055803 Mosaico Gold tessera 5x5 . 2"x2" ● B13

Pezzi Speciali . Trims . Pièces Spéciales . Formstücke . Специальные изделия



Battiscopa 9x118 . 3 9/16"x46 7/16" ► C7

1055810 White  
1055806 Black  
1055807 Brown  
1055808 Gold



Gradone Costa Retta (comp. 2 pz) 36x118x3,3 . 14 3/16"x46 7/16"x1 5/16" ● B50

1058872 White  
1058873 Black  
1058874 Brown  
1058876 Gold



Gradone Square Assemblato (comp. 2 pz) 36x118x3,3 . 14 3/16"x46 7/16"x1 5/16" ● B61

1055815 White  
1055811 Black  
1055812 Brown  
1055813 Gold

	BOX			PALLET		
	PZ	SQM	KGS	BOXES	SQM	KGS
18x118 . 7 1/6"x46 7/16"	5	1,06	21,50	36	38,16	790
Battiscopa 9x118 . 3 9/16"x46 7/16"	6	7,08 ml	14,50			
Gradone Costa Retta 36x118x3,3 . 14 3/16"x46 7/16"x1 5/16"	comp 2		24,00			
Gradone Square Assemblato 36x118x3,3 . 14 3/16"x46 7/16"x1 5/16"	comp 2		25,00			



Black 18x118 . 7 1/6"x46 7/16" / Wall12 Fabolous Blue 60x120 . 24"x48" rett (collezione Showall, pag. 220)



Canalgrande

Canalgrande 40x80 . 16"x32" rett / London Canalgrande 5,5x40 . 2 3/16"x16" rett / Diamonds 40x80 . 16"x32" rett  
 Alzata Canalgrande 15x40 . 6"x16" rett / Canalgrande 60x60 . 24"x24" rett / Diamonds 60x60 . 24"x24" rett

60x120 24"x48"  
 60x60 24"x24"  
 40x80 16"x32"

# CANALGRANDE







Canalgrande 60x120 . 24"x48" lux-rett / Mosaico Hive 30x30 . 12"x12" lux-rett



Canalgrande 60x60 - 24"x24" lux-rett / Battiscopa 6,5x60 - 2 9/16"x24" lux-rett

# CANALGRANDE

10 mm spessore . thickness . épaisseur . stärke . толщина

10,5 mm spessore . thickness . épaisseur . stärke . толщина

10 mm 10,5 mm R9 V2 60x60 - 24"x24" . 60x120 - 24"x48" . 40x80 - 16"x32"

## Colours

### Canalgrande

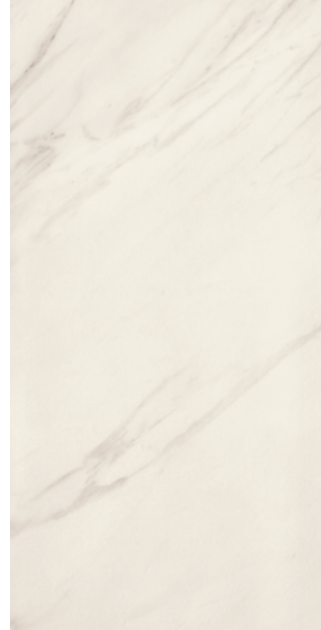

**1049643**  
60x120 . 24"x48" rett ■ **A31**  
**1049777**  
60x120 . 24"x48" lux-rett ■ **A42**

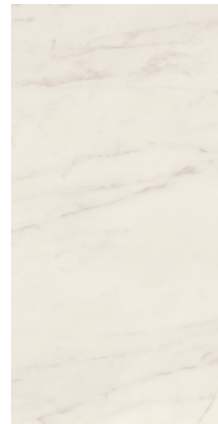

**1049865**  
40x80 . 16"x32" ■ **A13**  
**1049637**  
40x80 . 16"x32" rett ■ **A17**  
**1049640**  
40x80 . 16"x32" lux-rett ■ **A32**

### Canalgrande Stone

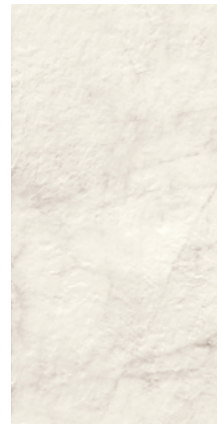

**1049774**  
40x80 . 16"x32" Stone ■ **A13**

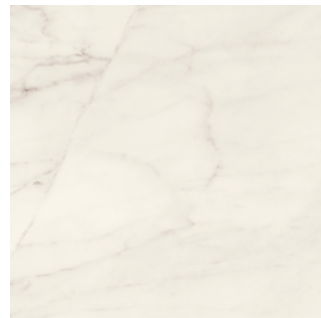

**1049634**  
60x60 . 24"x24" rett ■ **A15**  
**1049776**  
60x60 . 24"x24" lux-rett ■ **A31**

### Pezzi Speciali . Trims . Pièces Spéciales . Formstücke . Специальные изделия



Battiscopa  
**1050079** 6,5x60 . 2 3/16"x24" rett ► **C5**  
**1050408** 6,5x60 . 2 3/16"x24" lux-rett ► **C6**

### Decori . Decors . Décors . Dekore . Декоры

#### Canalgrande Diamonds

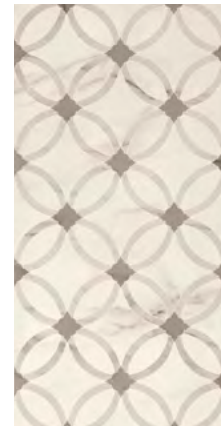

**1049646** Diamonds  
40x80 . 16"x32" rett ■ **A25**

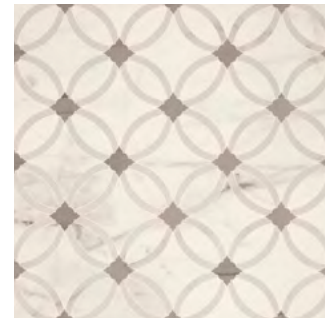

**1049644** Diamonds  
60x60 . 24"x24" rett ■ **A23**



London Canalgrande  
**1050035**  
5,5x40 . 2 3/16"x16" rett ■ **B20**  
**1050034**  
5,5x40 . 2 3/16"x16" lux-rett ■ **B22**

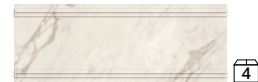

Alzata Canalgrande  
**1050037**  
15x40 . 6"x16" rett ■ **B28**  
**1050036**  
15x40 . 6"x16" lux-rett ■ **B30**

### Mosaici . Mosaics . Mosaïques . Mosaiken . Мозаика

#### 30x30 - 12"x12" Foglio . Sheet . Feuille . Blatt . Лист



**1049912** Mosaico Canalgrande  
tessera 5x5 . 2"x2" ■ **B13**



**1049913** Mosaico Canalgrande Stone  
tessera 5x5 . 2"x2" ■ **B13**



**1049915** Mosaico Hexagone Idr.  
lux-rett ■ **B27**



**1049914** Mosaico Hive Idr.  
lux-rett ■ **B33**



**1049917** Mosaico Wave M. ■ **B16**



**1049916** Mosaico Wave B. ■ **B16**



**1050891** Kit chiusura  
Mosaico Wave ■ **B20**



**1050891** Kit chiusura  
Mosaico Wave ■ **B20**



**1052879** Mosaico Intreccio Cold  
(11,5 pz al mq) ■ **B29**



**1052880** Mosaico Intreccio Warm  
(11,5 pz al mq) ■ **B29**

	BOX			PALLET		
	PZ	SQM	KGS	BOXES	SQM	KGS
60x120 . 24"x48" lux-rett	2	1,44	32,40	21	30,24	700
	2	1,44	32,40	30	43,20	988
	2	1,44	32,40	36	51,84	1.182
60x120 . 24"x48" rett	2	1,44	32,60	21	30,24	710
	2	1,44	32,60	30	43,20	994
	2	1,44	32,60	36	51,84	1.190
60x60 . 24"x24" lux-rett	3	1,08	23,80	32	34,56	780
	3	1,08	23,80	40	43,20	968
60x60 . 24"x24" rett / Diamonds	3	1,08	24,00	32	34,56	790
	3	1,08	24,00	40	43,20	976
40x80 . 16"x32" lux-rett / rett / Diamonds	3	0,96	20,20	28	26,88	600
40x80 . 16"x32" / Stone	3	0,96	21,00	28	26,88	610
Battiscopa 6,5x60 . 2 3/16"x24" lux-rett / rett	12	7,20	11,00			

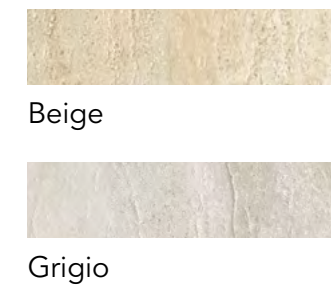

Grigio 45x90 . 18"x36" lux-rett / Battiscopa 7,5x60 . 3"x24" lux-rett

- 45x90 18"x36"
- 60x60 24"x24"
- 30x60 12"x24"
- 30,4x60,8 12"x24"

# I TRAVERTINI

# I TRAVERTINI

10 mm spessore . thickness . épaisseur . stärke . толщина

10mm R9 R10 V2 45x90 - 18"x36" . 60x60 - 24"x24" . 30x60 - 12"x24" . 30,4x60,8 - 12"x24"

## Colours

### Beige



1038805 60x60 . 24"x24" rett ■ A15  
1038804 60x60 . 24"x24" lux-rett ■ A31



1038106 45x90 . 18"x36" rett ■ A20  
1038107 45x90 . 18"x36" lux-rett ■ A29



1036717 30,4x60,8 . 12"x24" nat ■ A3  
1036719 30x60 . 12"x24" lux-rett ■ A27

### Grigio

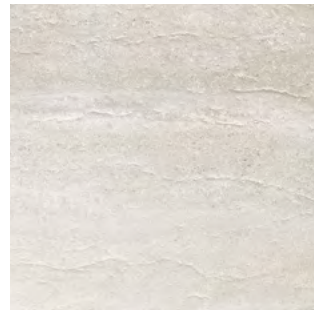

1043608 60x60 . 24"x24" rett ■ A15  
1043011 60x60 . 24"x24" lux-rett ■ A31

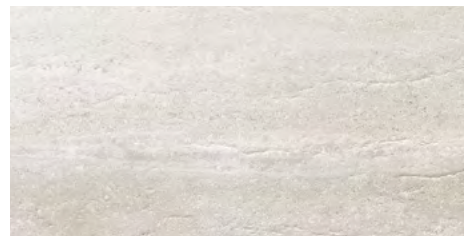

1043009 45x90 . 18"x36" rett ■ A20  
1043007 45x90 . 18"x36" lux-rett ■ A29

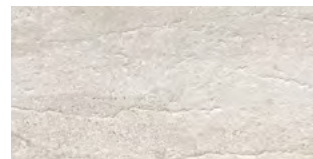

1043015 30,4x60,8 . 12"x24" nat ■ A3  
1043013 30x60 . 12"x24" lux-rett ■ A27

Mosaici . Mosaics . Mosaïques . Mosaiken . Мозаика

30x30 - 12"x12" Foglio . Sheet . Feuille . Blatt . Лист



1036696 Mosaico Travertino mix Beige-Crema tessera 2,2x2,2 . 7/8"x7/8" lux-rett ■ B22

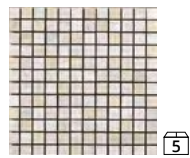

1043733 Mosaico Travertino mix Grigio-Crema tessera 2,2x2,2 . 7/8"x7/8" lux-rett ■ B22



1038235 Mosaico Intreccio Beige rett ■ B16 (Tozzetto Crema)



1043740 Mosaico Intreccio Grigio rett ■ B16 (Tozzetto Crema)



1038238 Mosaico Intreccio Beige lux-rett ■ B17 (Tozzetto Makori lapp)



1043741 Mosaico Intreccio Grigio lux-rett ■ B17 (Tozzetto Crema)

Decori . Decors . Décors . Dekore . Декоры

### Travertino



1038727 Fascia Travertino Beige 8,5x30 . 3 3/8"x12" lux-rett ■ B21



1043176 Fascia Travertino Grigio 8,5x30 . 3 3/8"x12" lux-rett ■ B21

Pezzi Speciali . Trims . Pièces Spéciales . Formstücke . Специальные изделия



Battiscopa 7,5x60 . 3"x24" rett ► C5  
1050348 Travertino Beige  
1050285 Travertino Grigio

Battiscopa 7,5x60 . 3"x24" lux-rett ► C6  
1050094 Travertino Beige  
1050600 Travertino Grigio



Beige 30x60 . 12"x24" lux-rett

	BOX			PALLET		
	PZ	SQM	KGS	BOXES	SQM	KGS
45x90 . 18"x36" lux-rett/rett	3	1,22	26,60	32	39,04	868
60x60 . 24"x24" lux-rett	3	1,08	23,80	32	34,56	780
	3	1,08	23,80	40	43,20	780
60x60 . 24"x24" rett	3	1,08	24,00	32	34,56	790
	3	1,08	24,00	40	43,20	976
30x60 . 12"x24" lux-rett	7	1,26	27,80	40	50,40	1.130
30,4x60,8 . 12"x24"	7	1,29	27,00	40	51,60	1.150
Battiscopa 7,5x60 . 3"x24" lux-rett/rett	12	7,20 ml	12,00			



Bianco 40x80 . 16"x32"



Bianco



Grigio



Crema



Noce

- 40x80 16"x32"
- 40x40 16"x16"
- 20x40 8"x16"
- 20x20 8"x8"
- 10x20 4"x8"

**DUOMO**



Crema 40x80 . 16"x32" / 10x20 . 4"x8"

Grigio 20x20 . 8"x8" / 10x20 . 4"x8" / 40x40 . 16"x16"

# DUOMO

10 mm spessore .  $\frac{3}{8}$ " thickness . épaisseur . stärke . толщина

10mm R10 V2 40x80 - 16"x32" . 40x40 - 16"x16" . 20x40 - 8"x16" . 20x20 - 8"x8" . 10x20 - 4"x8"

## Colours

### Bianco



1049794 40x80 . 16"x32"  
■ A14

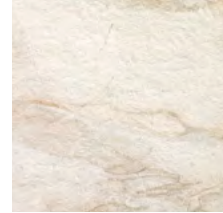

1049783 40x40 . 16"x16"  
■ A8



1049798 20x40 . 8"x16"  
■ A8



1049802 20x20 . 8"x8"  
■ A8



1049806 10x20 . 4"x8"  
■ A11

### Grigio



1049796 40x80 . 16"x32"  
■ A14

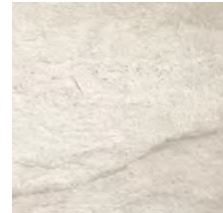

1049785 40x40 . 16"x16"  
■ A8

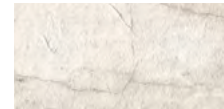

1049800 20x40 . 8"x16"  
■ A8



1049804 20x20 . 8"x8"  
■ A8

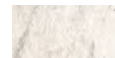

1049808 10x20 . 4"x8"  
■ A11

### Crema

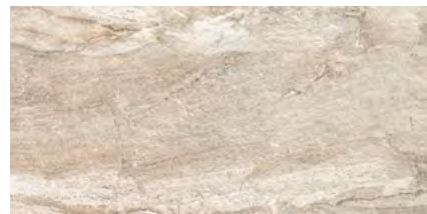

1049795 40x80 . 16"x32"  
■ A14

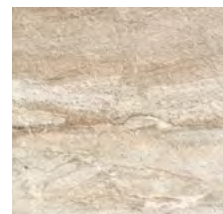

1049784 40x40 . 16"x16"  
■ A8

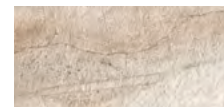

1049799 20x40 . 8"x16"  
■ A8



1049803 20x20 . 8"x8"  
■ A8



1049807 10x20 . 4"x8"  
■ A11

### Noce

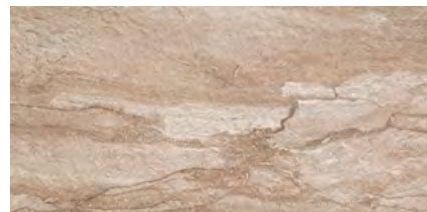

1049797 40x80 . 16"x32"  
■ A14

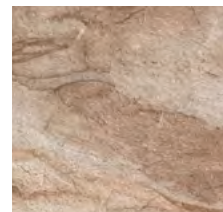

1049786 40x40 . 16"x16"  
■ A8

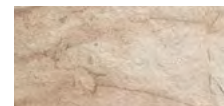

1049801 20x40 . 8"x16"  
■ A8



1049805 20x20 . 8"x8"  
■ A8



1049809 10x20 . 4"x8"  
■ A11

### Pezzi Speciali . Trims . Pièces Spéciales . Formstücke . Специальные изделия



Battiscopa  
6,5x40 . 2 9/16"x16" ► C3

1050081 Bianco  
1050082 Crema

1050083 Grigio  
1050084 Noce

### Mosaici . Mosaics . Mosaïques . Mosaiken . Мозаика

#### 30x30 - 12"x12" Foglio . Sheet . Feuille . Blatt . Лист

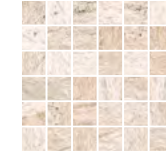

1049829 Mosaico  
Duomo Bianco  
tessera 5x5 . 2"x2" ● B13

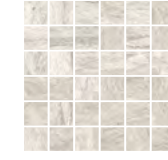

1049831 Mosaico  
Duomo Grigio  
tessera 5x5 . 2"x2" ● B13

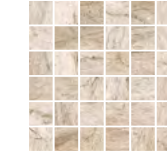

1049830 Mosaico  
Duomo Crema  
tessera 5x5 . 2"x2" ● B13

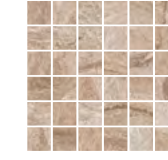

1049832 Mosaico  
Duomo Noce  
tessera 5x5 . 2"x2" ● B13



Noce 40x40 . 16"x16" / 10x20 . 4"x8" / Battiscopa 6,5x40 . 2 9/16"x16"

	BOX			PALLET		
	PZ	SQM	KGS	BOXES	SQM	KGS
40x80 . 16"x32"	3	0,96	19,50	28	26,88	565
40x40 . 16"x16"	8	1,28	25,60	48	61,44	1.245
20x40 . 8"x16"	13	1,04	20,80	54	56,16	1.130
20x20 . 8"x8"	26	1,04	20,80	54	56,16	1.130
10x20 . 4"x8"	36	0,72	14,40	72	51,84	1.055
Battiscopa 6,5x40 . 2 9/16"x16"	20	8,00 ml	10,00			



Shabby Chic 40x40 . 16"x16" / Fabric Mix Shabby Chic 40x40 . 16"x16"



Classic



Feng Shui



Industrial



Minimal



Natural

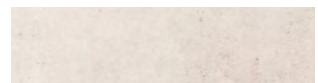

Shabby Chic

# RIABITA IL COTTO

60,8x60,8 24"x24"

40x80 16"x32"

40x40 16"x16"

20x40 8"x16"

20x20 8"x8"





194

195

Natural 60,8x60,8 . 24"x24"

Minimal 20x40 . 8"x16" / 40x40 . 16"x16" / 40x80 . 16"x32"



196

Feng Shui 40x40 . 16"x16" / Fabric Mix Feng Shui 40x40 . 16"x16"



197

Classic 40x40 . 16"x16"

# RIABITA IL COTTO

10 mm spessore .  $\frac{3}{8}$ "  
 spessore . thickness . épaisseur . stärke . толщина

10mm R10 R11 V3 60,8x60,8 - 24"x24" . 40x80 - 16"x32" . 40x40 - 16"x16" . 20x40 - 8"x16" . 20x20 - 8"x8"

## Colours

### Classic



1048218 60,8x60,8 . 24"x24" ■ A10



1046385 40x40 . 16"x16" ■ A8

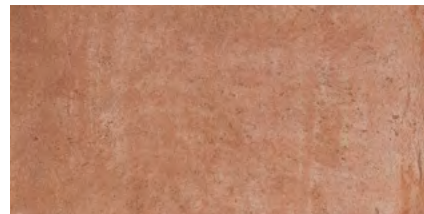

1046380 40x80 . 16"x32" ■ A14



1046391 20x40 . 8"x16" ■ A8



1046685 20x20 . 8"x8" ■ A8

### Feng Shui



1048219 60,8x60,8 . 24"x24" ■ A10



1046387 40x40 . 16"x16" ■ A8

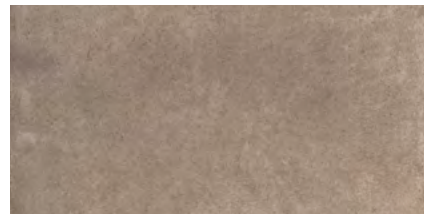

1046381 40x80 . 16"x32" ■ A14

### Industrial



1048220 60,8x60,8 . 24"x24" ■ A10



1046388 40x40 . 16"x16" ■ A8

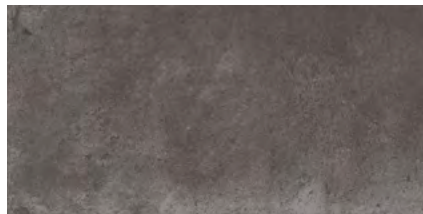

1046382 40x80 . 16"x32" ■ A14

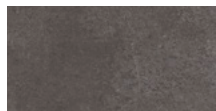

1046393 20x40 . 8"x16" ■ A8



1046687 20x20 . 8"x8" ■ A8

### Minimal



1048221 60,8x60,8 . 24"x24" ■ A10



1046481 40x40 . 16"x16" ■ A8  
 1047113 40x40 . 16"x16" R11 ■ A10

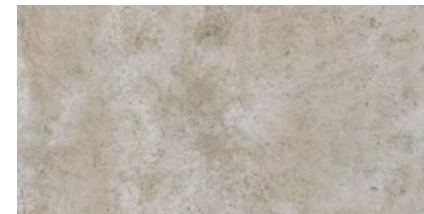

1046483 40x80 . 16"x32" ■ A14  
 1047112 40x80 . 16"x32" R11 ■ A15

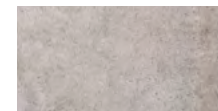

1046480 20x40 . 8"x16" ■ A8

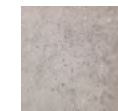

1046688 20x20 . 8"x8" ■ A8

### Natural



1048222 60,8x60,8 . 24"x24" ■ A10

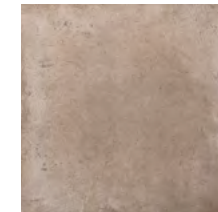

1046389 40x40 . 16"x16" ■ A8

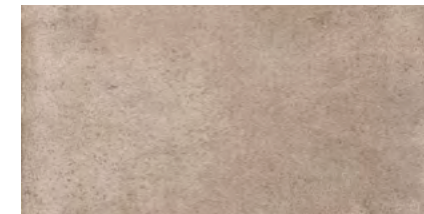

1046383 40x80 . 16"x32" ■ A14



1046394 20x40 . 8"x16" ■ A8



1046689 20x20 . 8"x8" ■ A8

### Shabby Chic



1048223 60,8x60,8 . 24"x24" ■ A10



1046390 40x40 . 16"x16" ■ A8  
 1047114 40x40 . 16"x16" R11 ■ A10

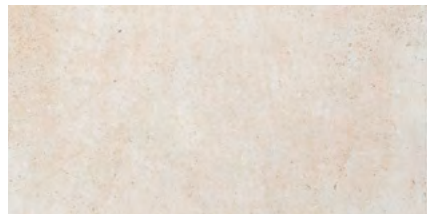

1046384 40x80 . 16"x32" ■ A14  
 1047070 40x80 . 16"x32" R11 ■ A15

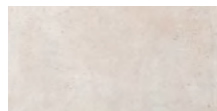

1046395 20x40 . 8"x16" ■ A8

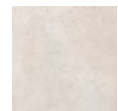

1046690 20x20 . 8"x8" ■ A8

## Pezzi Speciali . Trims . Pièces Spéciales . Formstücke . Специальные изделия



Battiscopa  
 6,5x40 . 2 9/16"x16" ► C3  
 1050095 Classic  
 1050096 Feng Shui  
 1050097 Industrial  
 1050098 Minimal  
 1050099 Natural  
 1050100 Shabby Chic



Battiscopa  
 6,5x60,8 . 2 9/16"x24" ► C4  
 1052997 Classic  
 1052998 Feng Shui  
 1050951 Industrial  
 1050417 Minimal  
 1050384 Natural  
 1050182 Shabby Chic



Gradone con frontale Monolitico  
 30x33x4,5 . 12"x13"x1 7/8" ► B33  
 1047465 Classic  
 1047495 Minimal  
 1047424 Natural  
 1047496 Shabby Chic



Angolare  
 33x33 . 13"x13" ► B40  
 1047466 Classic  
 1047497 Minimal  
 1047498 Natural  
 1047499 Shabby Chic



Battiscopa Scala (comp 2 pz)  
 6,5x40 . 2 9/16"x16" ► B16  
 1050470 Classic Dx  
 1050471 Classic Sx  
 1053535 Minimal Dx  
 1053536 Minimal Sx  
 1050551 Natural Dx  
 1050552 Natural Sx  
 1053422 Shabby Chic Dx  
 1050966 Shabby Chic Sx

# RIABITA IL COTTO

10 mm spessore - 3/8" thickness - épaisseur - stärke - толщина

10mm R10 R11 V3 60,8x60,8 - 24"x24" . 40x80 - 16"x32" . 40x40 - 16"x16" . 20x40 - 8"x16" . 20x20 - 8"x8"

## Fabric Mix \*

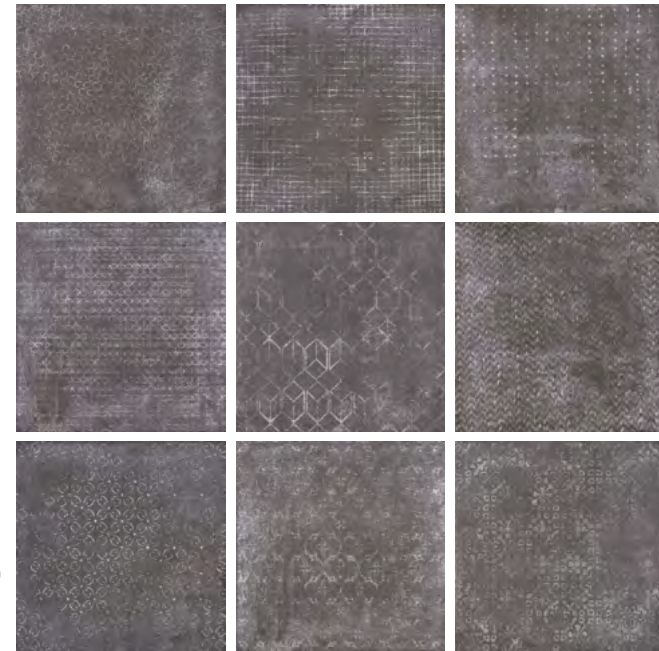

Fabric (9 soggetti mix)  
40x40 . 16"x16"

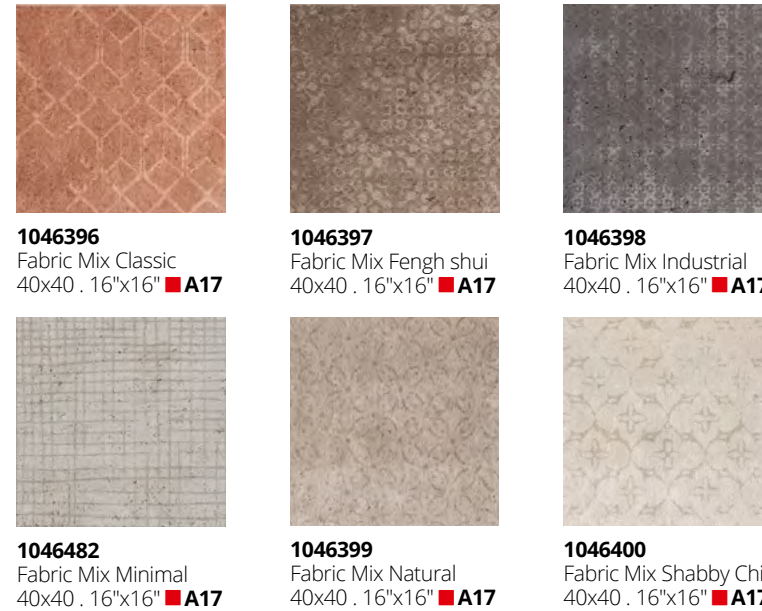

**1046396** Fabric Mix Classic 40x40 . 16"x16" ■ **A17**  
**1046397** Fabric Mix Feng shui 40x40 . 16"x16" ■ **A17**  
**1046398** Fabric Mix Industrial 40x40 . 16"x16" ■ **A17**  
**1046482** Fabric Mix Minimal 40x40 . 16"x16" ■ **A17**  
**1046399** Fabric Mix Natural 40x40 . 16"x16" ■ **A17**  
**1046400** Fabric Mix Shabby Chic 40x40 . 16"x16" ■ **A17**

\* Soggetti miscelati casualmente nelle scatole.  
 \* Designs available with each box containing a random mix.  
 \* Motifs mélangés au hasard dans les boîtes.  
 \* Muster in den Schachteln werden nach den Zufallsprinzip gemischt.  
 \* Вариантов, в коробке упакована произвольная смесь из них.

## Mosaici . Mosaics . Mosaïques . Mosaiken . Мозаика

30x30 - 12"x12" Foglio. Sheet. Feuille. Blatt. Лист

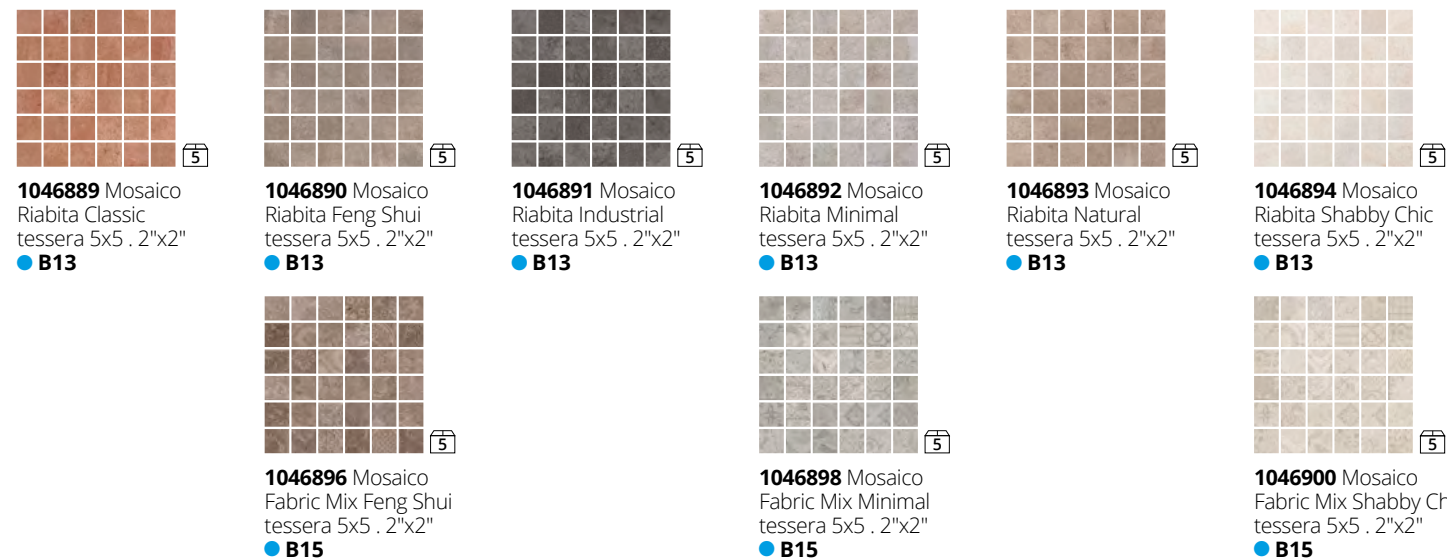

**1046889** Mosaico Riabita Classic tessera 5x5 . 2"x2" ■ **B13**  
**1046890** Mosaico Riabita Feng Shui tessera 5x5 . 2"x2" ■ **B13**  
**1046891** Mosaico Riabita Industrial tessera 5x5 . 2"x2" ■ **B13**  
**1046892** Mosaico Riabita Minimal tessera 5x5 . 2"x2" ■ **B13**  
**1046893** Mosaico Riabita Natural tessera 5x5 . 2"x2" ■ **B13**  
**1046894** Mosaico Riabita Shabby Chic tessera 5x5 . 2"x2" ■ **B13**  
**1046896** Mosaico Fabric Mix Feng Shui tessera 5x5 . 2"x2" ■ **B15**  
**1046898** Mosaico Fabric Mix Minimal tessera 5x5 . 2"x2" ■ **B15**  
**1046900** Mosaico Fabric Mix Shabby Chic tessera 5x5 . 2"x2" ■ **B15**

## Decori . Decors . Décors . Dekore . Декоры

### Vanity

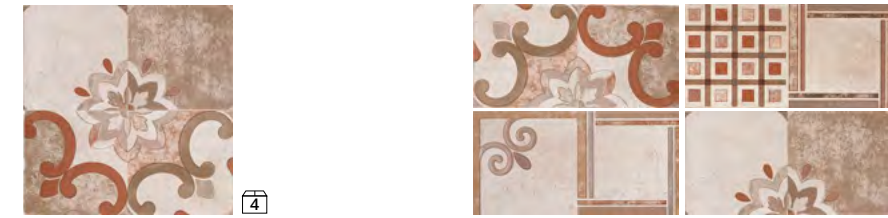

**1046334** Inserto Vanity Warm S/1 Pz ■ **B36**  
**1047754** Inserto Vanity Warm S/1 Mq ■ **A60**  
**1046336** Inserto Vanity Warm s/4 20x40 . 8"x16" ■ **B19**

### New Glam

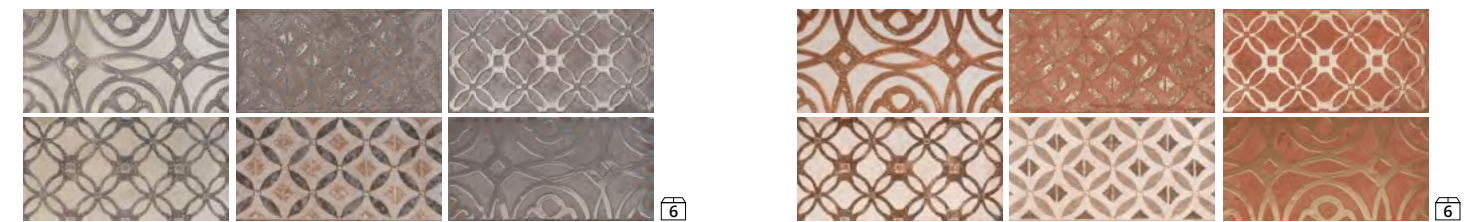

**1046816** Inserto New Glam Cold s/6 20x40 . 8"x16" ■ **B17**  
**1046817** Inserto New Glam Warm s/6 20x40 . 8"x16" ■ **B17**

### Pattern



**1047120** Inserto Pattern Grey S/4 Pz ■ **B30**  
**1047041** Inserto Pattern Grey S/4 Mq ■ **A53**  
**1047118** Inserto Pattern Beige S/4 Pz ■ **B30**  
**1047040** Inserto Pattern Beige S/4 Mq ■ **A53**

	BOX			PALLET		
	PZ	SQM	KGS	BOXES	SQM	KGS
60,8x60,8 . 24"x24"	3	1,11	25,00	32	35,52	822
40x80 . 16"x32"	3	0,96	21,60	28	26,88	621
40x40 . 16"x16" / Fabric	7	1,12	25,00	48	53,76	1.216
20x40 . 8"x16"	12	0,96	21,00	54	51,84	1.150
20x20 . 8"x8"	24	0,96	20,30	54	51,84	1.112
Battiscopa 6,5x40 . 2 9/16"x16"	20	8,00 ml	11,50			
Battiscopa 6,5x60,8 . 2 9/16"x24"	12	7,30 ml	10,50			
Gradone con frontale Monolitico 30x33x4,5 . 12"x13" x1 7/8"	6		16,80			
Angolare 33x33 . 13"x13"	4		13,60			
Battiscopa scala comp. 2 pz 6,5x40 . 2 9/16"x16"	comp 7		10,00			



Abbadia



Borgo



Spada

Spada 48x48 . 19"x19" / 15,8x31,7 . 6<sup>3/16</sup>"x12<sup>1/2</sup>"

- 48x48 19"x19"
- 31,7x48 12<sup>1/2</sup>"x19"
- 31,7x31,7 12<sup>1/2</sup>"x12<sup>1/2</sup>"
- 15,8x31,7 6<sup>3/16</sup>"x12<sup>1/2</sup>"
- 15,8x15,8 6<sup>3/16</sup>"x6<sup>3/16</sup>"

# QUINTANA

# QUINTANA

10,5 mm - 3/8"  
spessore . thickness . épaisseur . stärke . толщина



48x48 - 19"x19" **31,7x48** - 12 1/2"x19" **31,7x31,7** - 12 1/2"x12 1/2"  
15,8x31,7 - 6 3/16"x12 1/2" **15,8x15,8** - 6 3/16"x6 3/16"

## Colours

### Abbadia



**1002912**  
48x48 . 19"x19" ■ **A7**



**1001198**  
31,7x48 . 12 1/2"x19" ■ **A4**

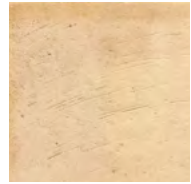

**1002911**  
31,7x31,7 . 12 1/2"x12 1/2" ■ **A1**



**1001201**  
Abbadia Campigiana  
15,8x31,7 . 6 3/16"x12 1/2" ■ **A2**



**1001197**  
15,8x15,8 . 6 3/16"x6 3/16" ■ **A8**

### Borgo



**1002917**  
48x48 . 19"x19" ■ **A7**



**1001206**  
31,7x48 . 12 1/2"x19" ■ **A4**



**1002916**  
31,7x31,7 . 12 1/2"x12 1/2" ■ **A1**



**1001209**  
Borgo Campigiana  
15,8x31,7 . 6 3/16"x12 1/2" ■ **A2**



**1001205**  
15,8x15,8 . 6 3/16"x6 3/16" ■ **A8**

### Spada



**1002942**  
48x48 . 19"x19" ■ **A7**



**1001232**  
31,7x48 . 12 1/2"x19" ■ **A4**



**1002941**  
31,7x31,7 . 12 1/2"x12 1/2" ■ **A1**



**1001235** Campigiana  
15,8x31,7 . 6 3/16"x12 1/2" ■ **A2**



**1001227**  
15,8x15,8 . 6 3/16"x6 3/16" ■ **A8**

## Mosaici . Mosaics . Mosaïques . Mosaiken . Мозаика

**31,7x31,7** - 12 1/2"x12 1/2" **Foglio. Sheet. Feuille. Blatt. Лист**



**1002935** Mosaico Saraceno Chiaro  
(Abbadia, Borgo) tessera 5x5 . 2"x2" ■ **B13**



**1002937** Mosaico Saraceno Scuro  
(Morlupo, Spada) tessera 5x5 . 2"x2" ■ **B13**

## Pezzi Speciali . Trims. Pièces Spéciales. Formstücke. Специальные изделия



**Battiscopa**  
8x31,7 . 3 3/16"x12 1/2" ► **C1**  
**1000983** Abbadia  
**1000984** Borgo  
**1000992** Spada



**Gradone con frontale monolitico**  
30x33x4,5 . 12"x13"x1 3/16" ● **B33**  
**1050577** Abbadia  
**1049514** Borgo  
**1048357** Spada



**Angolare**  
33x33 . 13"x13" ● **B40**  
**1050578** Abbadia  
**1049515** Borgo  
**1048358** Spada



**Battiscopa Scala dx/sx (comp 2 pz)**  
8x31,7 . 3 3/16"x12 1/2" ● **B14**  
**1003600** Abbadia Dx  
**1003601** Abbadia Sx  
**1003603** Borgo Dx  
**1003604** Borgo Sx  
**1003621** Spada Dx  
**1003622** Spada Sx



MODULARE 1: Abbadia 48x48 . 19"x19" / 31,7x48 . 12 1/2"x19" / 31,7x31,7 . 12 1/2"x12 1/2" / 15,8x31,7 . 6 3/16"x12 1/2" / 15,8x15,8 . 6 3/16"x6 3/16"

	BOX			PALLET		
	PZ	SQM	KGS	BOXES	SQM	KGS
48x48 . 19"x19"	5	1,152	26,00	28	32,26	744
31,7x48 . 12 1/2"x19"	6	0,913	21,70	44	40,17	971
31,7x31,7 . 12 1/2"x12 1/2"	10	1,005	22,00	48	48,24	1.072
15,8x31,7 . 6 3/16"x12 1/2"	14	0,70	16,00	68	47,60	1.104
15,8x15,8 . 6 3/16"x6 3/16"	28	0,70	15,00	85	59,50	1.291
Battiscopa 8x31,7 . 3 3/16"x12 1/2"	30	9,51 ml	11,60			
Battiscopa Scala comp 2 pz 8x31,7 . 3 3/16"x12 1/2"	comp 6		5,40			
Gradone con frontale monolitico 30x33x4,5 . 12"x13"x1 3/16"	6		16,80			
Angolare 33x33 . 13"x13"	4		13,60			



PF Grise 60x60 . 24"x24" rett



PF Antra



PF Blanche



PF Grise









PF Naturelle

# PIERRE DE FRANCE

- 80x80 32"x32"
- 60x120 24"x48"
- 60x60 24"x24"
- 40x60,8 16"x24"

# PIERRE DE FRANCE

10 mm spessore . *thickness* . épaisseur . stärke . толщина







**80x80** - 32"x32" . **60x120** - 24"x48" . **60x60** - 24"x24" . **40x60,8** - 16"x24"

## Colours

### PF Blanche



**1055101** PF Blanche  
80x80 . 32"x32" rett ■ **A27**

### PF Grise



**1055103** PF Grise  
80x80 . 32"x32" rett ■ **A27**

### PF Naturelle



**1055957** PF Naturelle  
60x60 . 24"x24" lapp-rett ■ **A24**  
**1055953** PF Naturelle  
60x60 . 24"x24" rett ■ **A15**

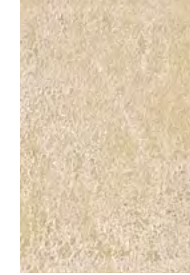

**1055012** PF Naturelle  
40x60,8 . 16"x24" ■ **A15**  
**1055017** PF Naturelle  
40x60,8 . 16"x24" R11 ■ **A17**

### PF Antra



**1055954** PF Antra  
60x60 . 24"x24" lapp-rett ■ **A24**  
**1055950** PF Antra  
60x60 . 24"x24" rett ■ **A15**



**1055008** PF Antra  
40x60,8 . 16"x24" ■ **A15**  
**1055013** PF Antra  
40x60,8 . 16"x24" R11 ■ **A17**

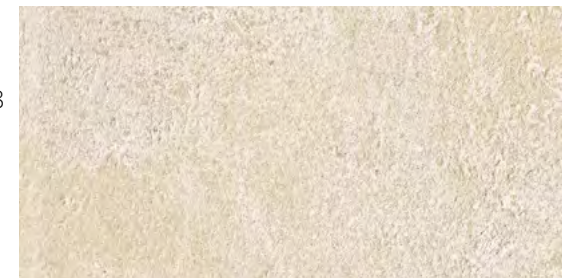

**1055959** PF Blanche  
60x120 . 24"x48" rett ■ **A31**



**1055960** PF Grise  
60x120 . 24"x48" rett ■ **A31**



**1055955** PF Blanche  
60x60 . 24"x24" lapp-rett ■ **A24**  
**1055951** PF Blanche  
60x60 . 24"x24" rett ■ **A15**

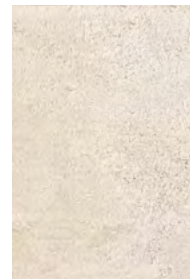

**1055009** PF Blanche  
40x60,8 . 16"x24" ■ **A15**  
**1055014** PF Blanche  
40x60,8 . 16"x24" R11 ■ **A17**



**1055956** PF Grise  
60x60 . 24"x24" lapp-rett ■ **A24**  
**1055952** PF Grise  
60x60 . 24"x24" rett ■ **A15**

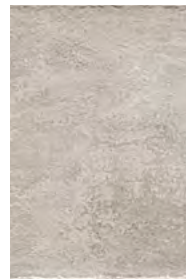

**1055011** PF Grise  
40x60,8 . 16"x24" ■ **A15**  
**1055016** PF Grise  
40x60,8 . 16"x24" R11 ■ **A17**

## Mosaici . Mosaics . Mosaïques . Mosaiken . Мозаика

### 30x30 - 12"x12" Foglio . Sheet . Feuille . Blatt . Лист



**1055690** Mosaico Blanche  
tessera 5x5 . 2"x2" lapp-rett ● **B16**  
**1055685** Mosaico Blanche  
tessera 5x5 . 2"x2" rett ● **B13**

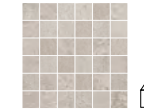

**1055692** Mosaico Grise  
tessera 5x5 . 2"x2" lapp-rett ● **B16**  
**1055687** Mosaico Grise  
tessera 5x5 . 2"x2" rett ● **B13**

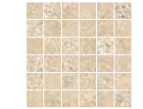

**1055693** Mosaico Naturelle  
tessera 5x5 . 2"x2" lapp-rett ● **B16**  
**1055688** Mosaico Naturelle  
tessera 5x5 . 2"x2" rett ● **B13**

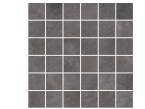

**1055689** Mosaico Antra  
tessera 5x5 . 2"x2" lapp-rett ● **B16**  
**1055684** Mosaico Antra  
tessera 5x5 . 2"x2" rett ● **B13**



**1055506** Mosaico Blanche  
spacco burattato irregolare  
32x32 . 12 5/8"x12 5/8" ● **B18**



**1055508** Mosaico Grise  
spacco burattato irregolare  
32x32 . 12 5/8"x12 5/8" ● **B18**



**1055509** Mosaico Naturelle  
spacco burattato irregolare  
32x32 . 12 5/8"x12 5/8" ● **B18**



**1055505** Mosaico Antra  
spacco burattato irregolare  
32x32 . 12 5/8"x12 5/8" ● **B18**



# PIERRE DE FRANCE

10 mm spessore .  $\frac{3}{8}$ "  
 spessore . thickness . épaisseur . stärke . толщина

10mm R10 R11 V4 80x80 - 32"x32" . 60x120 - 24"x48" . 60x60 - 24"x24" . 40x60,8 - 16"x24"

## Pezzi Speciali . Trims . Pièces Spéciales . Formstücke . Специальные изделия



Battiscopa  
 6,5x60 . 2  $\frac{9}{16}$ "x24" lapp-rett ► C6  
**1056108** Antra  
**1056109** Blanche  
**1056110** Grise  
**1056111** Naturelle



Battiscopa  
 6,5x60 . 2  $\frac{9}{16}$ "x24" rett ► C5  
**1055706** Antra  
**1055707** Blanche  
**1055709** Grise  
**1055710** Naturelle



Battiscopa  
 7,5x80 . 3"x32" rett ► C7  
**1056114** Blanche  
**1056116** Grise

Elemento ad "L" Assemblato  
 15x60,8x5 . 6"x24"x2" R11 ► B27  
**1058809** Antra  
**1058819** Blanche  
**1058820** Grise  
**1058821** Naturelle



Gradone Costa Retta  
 30x120x3,3 - 12"x48"x1  $\frac{5}{16}$ " rett ► B51  
**1058824** Blanche  
**1058825** Grise



Gradone Square Assemblato  
 30x120x3,3 - 12"x48"x1  $\frac{5}{16}$ " rett ► B62  
**1063194** Blanche  
**1063195** Grise

210

	BOX			PALLET		
	PZ	SQM	KGS	BOXES	SQM	KGS
80x80 . 32"x32" lapp-rett	2	1,28	28,30	40	51,20	1.150
80x80 . 32"x32" rett	2	1,28	28,50	40	51,20	1.160
60x120 . 24"x48" lapp-rett	2	1,44	31,50	21	30,24	680
	2	1,44	31,50	36	51,84	1.150
60x120 . 24"x48" rett	2	1,44	31,70	21	30,24	690
	2	1,44	31,70	36	51,84	1.157
60x60 . 24"x24" lapp-rett	3	1,08	23,30	32	34,56	760
	3	1,08	23,30	40	43,20	948
60x60 . 24"x24" rett	3	1,08	23,50	32	34,56	770
	3	1,08	23,50	40	43,20	956
40x60,8 . 16"x24"	4	0,97	21,50	30	29,10	670
40x60,8 . 16"x24" R11	4	0,97	21,50	30	29,10	670
Battiscopa 6,5x60 . 2 $\frac{9}{16}$ "x24" rett	12	7,20 ml	11,00			
Battiscopa 7,5x80 . 3"x32" rett	6	4,80 ml	8,50			
Elemento a "L" Assemblato R11 15x60,8x5 . 6"x24"x2"	4		11,50			
Gradone Costa Retta 30x120x3,3 . 12"x48"x1 $\frac{5}{16}$ " rett	2		17,40			
Gradone Square Assemblato 30x120x3,3 . 12"x48"x1 $\frac{5}{16}$ " rett	2		19,00			



211



Cluny 40x80 . 16"x32" / Mosaico Spacco Cluny 7,5x7,5 . 3"x3"



Auxerre



Cluny



Nevers

# DUCATO DI BORGOGNA

40x80 16"x32"

40x40 16"x16"



# DUCATO DI BORGOGNA

10 mm spessore - 3/8" thickness . épaisseur . stärke . толщина

10mm R10 V4 40x80 - 16"x32" . 40x40 - 16"x16"

## Colours

### Auxerre



1050655 40x80 . 16"x32" ■ A14  
1050715 40x80 . 16"x32" lapp ■ A32



1050660 40x40 . 16"x16" ■ A8  
1050710 40x40 . 16"x16" lapp ■ A27

### Cluny



1050656 40x80 . 16"x32" ■ A14  
1050716 40x80 . 16"x32" lapp ■ A32



1050661 40x40 . 16"x16" ■ A8  
1050711 40x40 . 16"x16" lapp ■ A27

### Nevers



1050658 40x80 . 16"x32" ■ A14  
1050718 40x80 . 16"x32" lapp ■ A32



1050663 40x40 . 16"x16" ■ A8  
1050713 40x40 . 16"x16" lapp ■ A27

- \* Soggetti miscelati casualmente nelle scatole.
- \* Designs available with each box containing a random mix.
- \* Motifs mélangés au hasard dans les boîtes.
- \* Muster in den Schachteln werden nach den Zufallsprinzip gemischt.
- \* Вариантов, в коробке упакована произвольная смесь из них.

## Mosaici . Mosaics . Mosaïques . Mosaiken . Мозаика

### 30x30 - 12"x12" Foglio. Sheet. Feuille. Blatt. Лист



1053574 Mosaico  
Borgogna Auxerre  
tessera 5x5 . 2"x2" ● B13

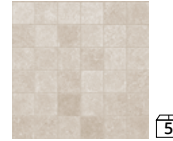

1053575 Mosaico  
Borgogna Cluny  
tessera 5x5 . 2"x2" ● B13



1053577 Mosaico  
Borgogna Nevers  
tessera 5x5 . 2"x2" ● B13

1053578 Mosaico  
Borgogna Auxerre  
tessera 5x5 . 2"x2" lapp ● B16

1053579 Mosaico  
Borgogna Cluny  
tessera 5x5 . 2"x2" lapp ● B16

1053581 Mosaico  
Borgogna Nevers  
tessera 5x5 . 2"x2" lapp ● B16

### 30x40 - 12"x16" Foglio. Sheet. Feuille. Blatt. Лист



1053583 Mosaico  
Spacco Auxerre  
tessera 7,5x7,5 . 3"x3" ● B15



1053584 Mosaico  
Spacco Cluny  
tessera 7,5x7,5 . 3"x3" ● B15



1053586 Mosaico  
Spacco Nevers  
tessera 7,5x7,5 . 3"x3" ● B15

## 214 Decori . Decors . Décors . Dekore . Декоры

### Frise Mix \*

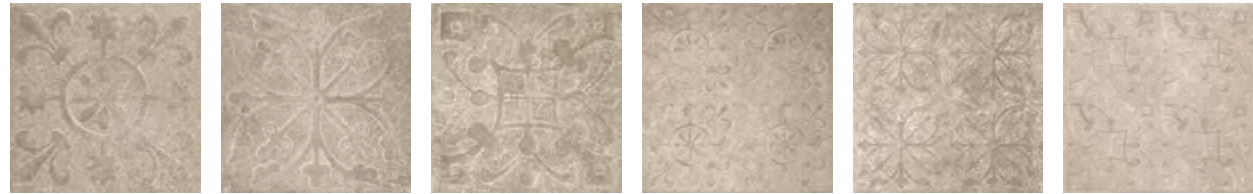

Frise Mix Auxerre (6 soggetti Mix)  
1050659 40x40 . 16"x16" ■ A13  
1050714 40x40 . 16"x16" lapp ■ A29



Frise Mix Cluny (6 soggetti Mix)  
1050752 40x40 . 16"x16" ■ A13  
1050755 40x40 . 16"x16" lapp ■ A29

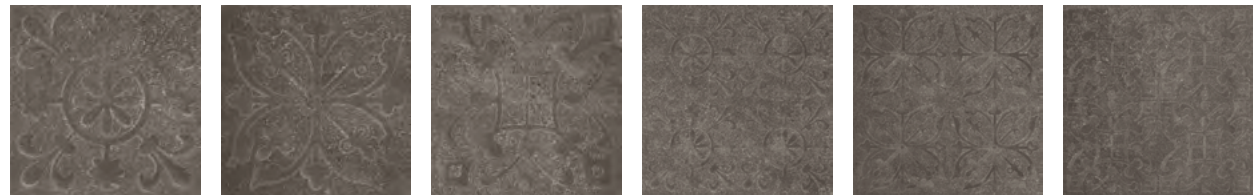

Frise Mix Nevers (6 soggetti Mix)  
1050754 40x40 . 16"x16" ■ A13  
1050757 40x40 . 16"x16" lapp ■ A29

215

## Pezzi Speciali . Trims . Pièces Spéciales . Formstücke . Специальные изделия



Battiscopa  
6,5x40 . 2 9/16"x16" ► C3  
1055423 Auxerre  
1055425 Cluny  
1055429 Nevers

Battiscopa  
6,5x40 . 2 9/16"x16" lapp ► C4  
1055424 Auxerre  
1055426 Cluny  
1055430 Nevers

	BOX			PALLET		
	PZ	SQM	KGS	BOXES	SQM	KGS
40x80 . 16"x32"	3	0,96	21,60	28	26,88	650
40x40 . 16"x16" / Frise Mix	8	1,28	27,60	48	61,44	1.350
Battiscopa 6,5x40 . 2 9/16"x16" lapp	20	8,00 ml	10,00			



Grey 30x60 . 12"x24" rett



Metro Sand



Metro Titan



Metro Grey

- 80x80 32"x32"
- 40x80 16"x32"
- 60x60 24"x24"
- 30x60 12"x24"

# METROPOLIS



# METROPOLIS

10 mm spessore . *thickness . épaisseur . stärke . толщина*

10mm R10 V2 80x80 - 32"x32" . 40x80 - 16"x32" . 60x60 - 24"x24" . 30x60 - 12"x24"

## Colours

### Metro Sand



1043530 80x80 . 32"x32" rett ■ A27

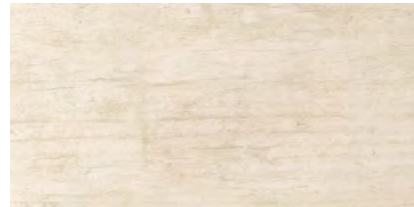

1043524 40x80 . 16"x32" rett ■ A25

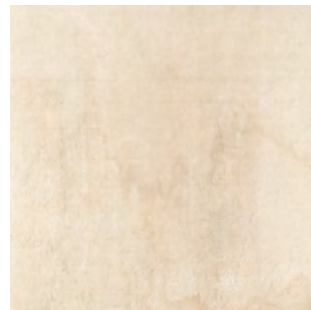

1043512 60x60 . 24"x24" rett ■ A15

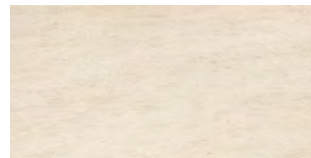

1043506 30x60 . 12"x24" rett ■ A10

### Metro Titan



1043532 80x80 . 32"x32" rett ■ A27



1043526 40x80 . 16"x32" rett ■ A25



1043514 60x60 . 24"x24" rett ■ A15

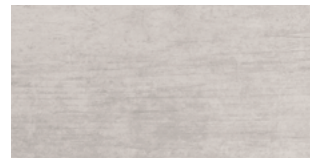

1043508 30x60 . 12"x24" rett ■ A10

### Metro Grey



1043529 80x80 . 32"x32" rett ■ A27



1043523 40x80 . 16"x32" rett ■ A25



1043511 60x60 . 24"x24" rett ■ A15

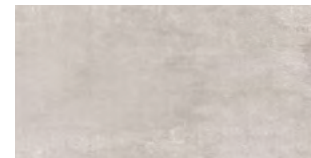

1043505 30x60 . 12"x24" rett ■ A10

## Mosaici . Mosaics . Mosaïques . Mosaiken . Мозаика

### 30x30 - 12"x12" Foglio . Sheet . Feuille . Blatt . Лист

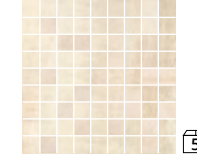

1045172 Mosaico Metro Sand tessera 3x3 1<sup>13</sup>/<sub>16</sub>"x1<sup>13</sup>/<sub>16</sub>" rett ● B16



1045174 Mosaico Metro Titan tessera 3x3 1<sup>13</sup>/<sub>16</sub>"x1<sup>13</sup>/<sub>16</sub>" rett ● B16



1045171 Mosaico Metro Grey tessera 3x3 1<sup>13</sup>/<sub>16</sub>"x1<sup>13</sup>/<sub>16</sub>" rett ● B16

## Pezzi Speciali . Trims . Pièces Spéciales . Formstücke . Специальные изделия



Battiscopa 6,5x60 . 2<sup>9</sup>/<sub>16</sub>"x24" rett ► C5  
1050418 Metro Grey  
1050106 Metro Sand  
1050416 Metro Titan



Battiscopa 7,5x80 . 3"x32" rett ► C7  
1050216 Metro Grey  
1050217 Metro Sand  
1050219 Metro Titan



Gradone Costa Retta 30x60x3,3 . 12"x24"x1<sup>5</sup>/<sub>16</sub>" rett ● B38  
1058843 Metro Grey  
1058844 Metro Sand  
1058846 Metro Titan

	BOX			PALLET		
	PZ	SQM	KGS	BOXES	SQM	KGS
80x80 . 32"x32" rett	2	1,28	28,50	40	51,20	1.160
40x80 . 16"x32" rett	3	0,96	21,50	28	26,88	620
60x60 . 24"x24" rett	3	1,08	23,50	32	34,56	770
	3	1,08	23,50	40	43,20	956
30x60 . 12"x24" rett	6	1,08	23,30	40	43,20	950
Battiscopa 6,5x60 . 2 <sup>9</sup> / <sub>16</sub> "x24" rett	12	7,20 ml	10,50			
Battiscopa 7,5x80 . 3"x32" rett	6	4,80 ml	9,00			
Gradone Costa Retta 30x60x3,3 . 12"x24"x1 <sup>5</sup> / <sub>16</sub> " rett	4		21,00			



# SHOWALL

✂ 10 mm <sup>3/8"</sup>  
 spessore . thickness . épaisseur . stärke . толщина

✂ 10 mm <sup>top</sup> ✂ 120x120 - 48"x48" . 60x120 - 24"x48"

## Wall01 Art Deco



Wall11 Art Deco  
**1069815** 60x120 . 24"x48" rett PZ ● B62C  
**1069816** 60x120 . 24"x48" rett MQ ■ A63

## Wall02 Myfair Grey



Wall02 Myfair Grey  
**1070215** 60x120 . 24"x48" rett PZ ● B62C  
**1070216** 60x120 . 24"x48" rett MQ ■ A63

## Wall03 Myfair White



Wall03 Myfair White  
**1070217** 60x120 . 24"x48" rett PZ ● B62C  
**1070218** 60x120 . 24"x48" rett MQ ■ A63

## Wall04 Hypnotic



Wall04 Hypnotic comp 2 PZ  
**1069817** 120x120 . 48"x48" rett COMP ● B66  
**1069818** 120x120 . 48"x48" rett MQ ■ A69

## Wall05 Mahori



Wall05 Mahori  
**1070288** 60x120 . 24"x48" rett COMP ● B62D  
**1070289** 60x120 . 24"x48" rett MQ ■ A66

## Wall06 Black Leaf



Wall06 Black Leaf comp 2 PZ  
**1069819** 120x120 . 48"x48" COMP ● B66  
**1069820** 120x120 . 48"x48" rett MQ ■ A69

# SHOWWALL

10 mm  
spessore . thickness . épaisseur . stärke . толщина

120x120 - 48"x48" . 60x120 - 24"x48"

## Colours

### Wall07 White Leaf



Wall07 White Leaf comp 2 PZ  
1069821 120x120 . 48"x48" rett COMP ● B67  
1069822 120x120 . 48"x48" rett MQ ■ A63A

### Wall08 Garden



Wall08 Garden comp 2 PZ  
1069823 120x120 . 48"x48" rett COMP ● B67  
1069824 120x120 . 48"x48" rett MQ ■ A63A

### Wall09 Jungle



Wall09 Jungle comp 2 PZ  
1069825 120x120 . 48"x48" rett COMP ● B67  
1069826 120x120 . 48"x48" rett MQ ■ A63A

### Wall13 Fenice



Wall13 Fenice comp. 2 pz  
1070292 120x120 . 48"x48" rett COMP ● B67  
1070293 120x120 . 48"x48" rett MQ ■ A63A

### Wall14 Forest



Wall14 Forest comp. 2 pz  
1070296 120x120 . 48"x48" rett COMP ● B67  
1070297 120x120 . 48"x48" rett MQ ■ A63A

### Wall10 Spring



Wall10 Spring  
1069827 60x120 . 24"x48" rett PZ ● B62D  
1069828 60x120 . 24"x48" rett MQ ■ A63A

### Wall11 Fabolous Pink



Wall11 Fabolous Pink  
1069829 60x120 . 24"x48" rett PZ ● B62C  
1069830 60x120 . 24"x48" rett MQ ■ A63

### Wall12 Fabolous Blue



Wall12 Fabolous Blue  
1069831 60x120 . 24"x48" rett PZ ● B62C  
1069832 60x120 . 24"x48" rett MQ ■ A63

### Wall15 Monkey



Wall15 Monkey comp. 2 pz  
1070301 120x120 . 48"x48" rett COMP ● B67  
1070303 120x120 . 48"x48" rett MQ ■ A63A

### Wall16 Romeo and Juliet



Wall16 Romeo and Juliet comp. 2 pz  
1070329 120x120 . 48"x48" rett COMP ● B67  
1070330 120x120 . 48"x48" rett MQ ■ A63A

	BOX		
	PZ	SQM	KGS
120x120 . 48"x48" rett	comp 1	1,44	32,00
60x120 . 24"x48" rett	2	1,44	32,00



Àcanto  
 Evoca  
 Promenade  
 Riabita il Cotto  
 Studio 50

**DICIANNOVE**

Studio 50 Peltro 100x100 . 40"x40" R11 19 mm rett

100x100 40"x40"  
 60x120 24"x48"  
 60x60 24"x24"



# ÀCANTO 19MM

19 mm - 13/16"  
spessore . thickness . épaisseur . stärke . толщина

19mm R11 V3 AirBuc 60x60 - 24"x24"

## Colours

### Grigio R11



1047682 60x60 . 24"x24"  
rett ■ A37

### Rovere R11



1047683 60x60 . 24"x24"  
rett ■ A37

226

## Pezzi Speciali . Trims . Pièces Spéciales . Formstücke . Специальные изделия



Step Molato R11  
30x60 . 12"x24" rett ● B36  
1050354 Grigio  
1049238 Rovere



Step Torato R11  
30x60 . 12"x24" rett ● B37  
1054648 Grigio  
1049760 Rovere



Elemento ad "L" Assemblato R11  
15x60x5 . 6"x24"x2" rett ● B45  
1058322 Grigio  
1055246 Rovere



Gradone Costa Retta R11  
35x60x5 . 13 3/4"x24"x2" rett ● B52  
1058894 Grigio  
1058895 Rovere



Griglia per Piscina R11  
20x60 . 8"x24" rett ● B56  
1058324 Grigio  
1058325 Rovere



Coppia Angolo Griglia (2 pz) R11  
20x60 . 8"x24" rett ● B63B  
1058327 Grigio  
1058328 Rovere

	BOX			PALLET		
	PZ	SQM	KGS	BOXES	SQM	KGS
60x60 . 24"x24" rett	2	0,72	30,60	32	23,04	996

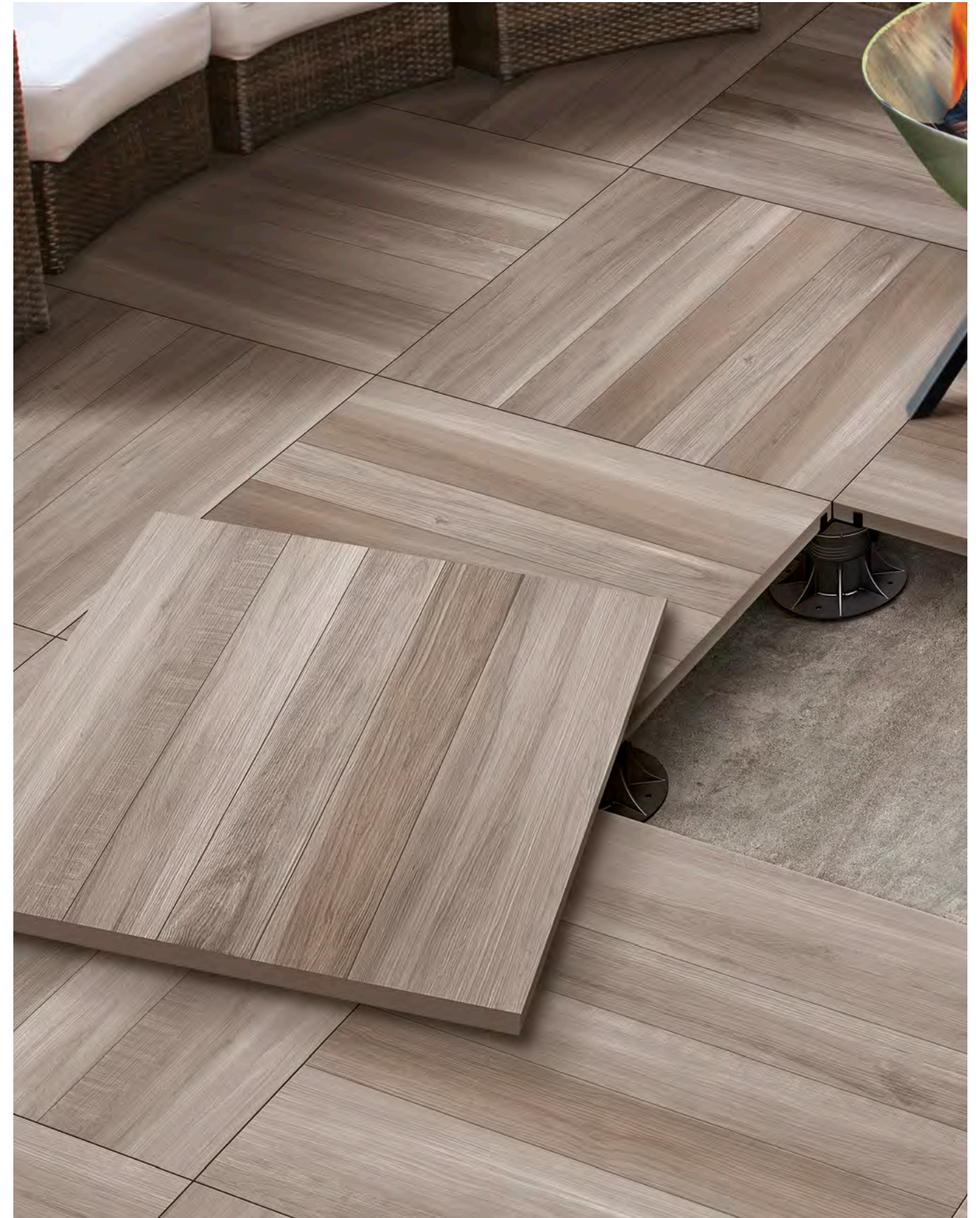

227

# EVOCA 19MM

19 mm - 13/16"  
spessore . thickness . épaisseur . stärke . толщина

19 mm R11 V2 60x120 - 24"x48"

## Colours

Evoca Ambra R11 Evoca Avorio R11 Evoca Cenere R11 Evoca Grafite R11 Evoca Terra R11

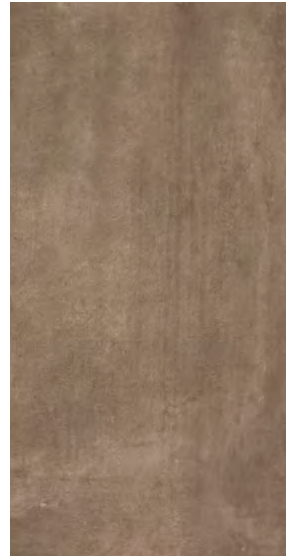

228 1065234 60x120 . 24"x48"  
rett ■ A46

1065235 60x120 . 24"x48"  
rett ■ A46

1065236 60x120 . 24"x48"  
rett ■ A46

1065237 60x120 . 24"x48"  
rett ■ A46

1065238 60x120 . 24"x48"  
rett ■ A46

Pezzi Speciali . Trims . Pièces Spéciales . Formstücke . Специальные изделия



Step Molato R11  
30x120 . 12"x48" rett ■ B53  
1065272 Ambra  
1065273 Avorio  
1065274 Cenere  
1065275 Grafite  
1065276 Terra

Step Torato R11  
30x120 . 12"x48" rett ■ B55  
1065277 Ambra  
1065278 Avorio  
1065279 Cenere  
1065280 Grafite  
1065281 Terra

Elemento ad "L" Assemblato R11  
15x60x5 . 6"x24"x2" rett ■ B45  
1065282 Ambra  
1065283 Avorio  
1065284 Cenere  
1065285 Grafite  
1065286 Terra

Gradone Costa Retta R11  
35x60x5 . 13 3/4"x24"x2" rett ■ B52  
1065287 Ambra  
1065288 Avorio  
1065289 Cenere  
1065290 Grafite  
1065291 Terra



Griglia per Piscina R11  
20x60 . 8"x24" rett ■ B56  
1065292 Ambra  
1065293 Avorio  
1065294 Cenere  
1065295 Grafite  
1065296 Terra

Coppia Angolo Griglia (2 pz) R11  
20x60 . 8"x24" rett ■ B63B  
1065297 Ambra  
1065298 Avorio  
1065299 Cenere  
1065300 Grafite  
1065301 Terra

	BOX			PALLET		
	PZ	SQM	KGS	BOXES	SQM	KGS
60x120 . 24"x48" rett	1	0,72	30,60	21	15,12	659



Cenere 60x120 . 24"x48" R11 19 MM rett  
Pezzi Speciali R11 19 MM

# PROMENADE19MM

19 mm - 13/16"  
spessore . thickness . épaisseur . stärke . толщина

19mm R11 V3 60x120 - 24"x48" . 60x60 - 24"x24"

## Colours

### Sabbia R11

### Corda R11

### Argento R11

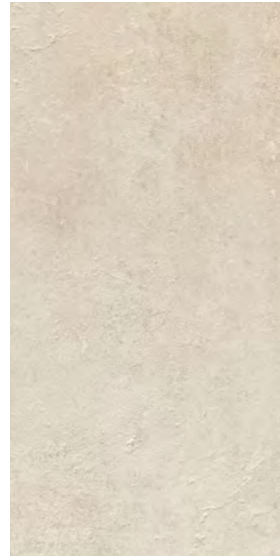

230 1068043 60x120 . 24"x48"  
rett ■ A46

1068042 60x120 . 24"x48"  
rett ■ A46

1068041 60x120 . 24"x48"  
rett ■ A46



1070527 60x60 . 24"x24"  
rett ■ A37

1070526 60x60 . 24"x24"  
rett ■ A37

1070525 60x60 . 24"x24"  
rett ■ A37

### Pezzi Speciali . Trims . Pièces Spéciales . Formstücke . Специальные изделия



Step Molato R11  
30x120 . 12"x48" rett ■ B53  
1070853 Sabbia  
1070852 Corda  
1070851 Argento



Step Torato R11  
30x120 . 12"x48" rett ■ B55  
1070856 Sabbia  
1070855 Corda  
1070854 Argento



Elemento ad "L" Assemblato R11  
15x60x5 . 6"x24"x2" rett ■ B45  
1070860 Sabbia  
1070859 Corda  
1070858 Argento



Gradone Costa Retta R11  
35x60x5 . 13 3/4"x24"x2" rett ■ B52  
1070863 Sabbia  
1070862 Corda  
1070861 Argento



Griglia per Piscina R11  
20x60 . 8"x24" rett ■ B56  
1070866 Sabbia  
1070865 Corda  
1070864 Argento



Coppia Angolo Griglia (2 pz) R11  
20x60 . 8"x24" rett ■ B63B  
1070869 Sabbia  
1070868 Corda  
1070867 Argento



Corda 60x120 . 24"x48" rett R11 19 MM

	BOX			PALLET		
	PZ	SQM	KGS	BOXES	SQM	KGS
60x120 . 24"x48" rett	1	0,72	30,60	36	25,92	1.118
60x60 . 24"x24" rett	2	0,72	30,60	32	23,04	996

# RIABITA IL COTTO 19MM

19 mm - 13/16"  
 spessore . thickness . épaisseur . stärke . толщина

19 mm  
**R11** V3 60x60 - 24"x24"

## Colours

### Classic R11



1047018 60x60 . 24"x24" rett ■ **A37**

### Natural R11



1047020 60x60 . 24"x24" rett ■ **A37**

### Minimal R11

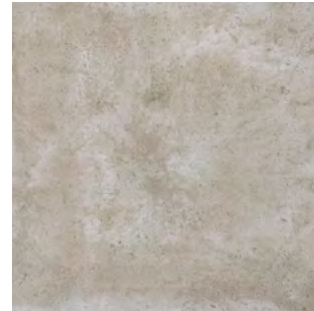

1047019 60x60 . 24"x24" rett ■ **A37**

## Pezzi Speciali . Trims. Pièces Spéciales. Formstücke. Специальные изделия



Step Molato R11  
 30x60 . 12"x24" rett ● **B36**  
**1054549** Classic  
**1049113** Minimal  
**1049649** Natural



Step Torato R11  
 30x60 . 12"x24" rett ● **B37**  
**1053564** Classic  
**1049493** Minimal  
**1053445** Natural



Elemento ad "L" Assemblato R11  
 15x60x5 . 6"x24"x2" rett ● **B45**  
**1048295** Classic  
**1056029** Minimal  
**1048141** Natural



Gradone Costa Retta R11  
 35x60x5 . 13 3/4"x24"x2" rett ● **B52**  
**1058896** Classic  
**1058897** Minimal  
**1058898** Natural



Griglia per Piscina R11  
 20x60 . 8"x24" rett ● **B56**  
**1058487** Classic  
**1058488** Minimal  
**1058489** Natural



Coppia Angolo Griglia (2 pz) R11  
 20x60 . 8"x24" rett ● **B63B**  
**1058493** Classic  
**1058495** Minimal  
**1058496** Natural

	BOX			PALLET		
	PZ	SQM	KGS	BOXES	SQM	KGS
60x60 . 24"x24" rett	2	0,72	30,60	32	23,04	996



Riabita il Cotto Minimal 60x60 . 24"x24" rett R11 19 MM

# STUDIO 5019MM

19 mm - 13/16"  
spessore . thickness . épaisseur . stärke . толщина

19mm R11 V2 100x100 - 40"x40" . 60x60 - 24"x24"

## Colours

### Studio Perla R11



1068439 100x100 . 40"x40" rett ■ A46E

### Studio Peltro R11



1068438 100x100 . 40"x40" rett ■ A46E

### Studio Verderame R11



1068442 100x100 . 40"x40" rett ■ A46E

### Studio Perla R11



1068444 60x60 . 24"x24" rett ■ A37

### Studio Peltro R11



1068443 60x60 . 24"x24" rett ■ A37

### Studio Verderame R11

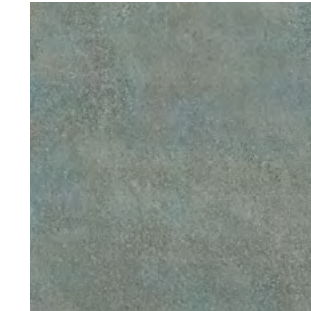

1068447 60x60 . 24"x24" rett ■ A37

### Studio Terracotta R11

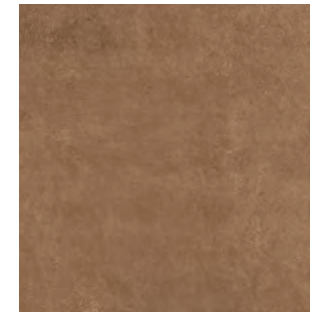

1068446 60x60 . 24"x24" rett ■ A37

### Studio Sabbia R11



1068445 60x60 . 24"x24" rett ■ A37

### Studio Terracotta R11



1068441 100x100 . 40"x40" rett ■ A46E

### Studio Sabbia R11



1068440 100x100 . 40"x40" rett ■ A46E

	BOX			PALLET		
	PZ	SQM	KGS	BOXES	SQM	KGS
100x100 40"x40" rett	1	1,00	42,50	21	21,00	926

	BOX			PALLET		
	PZ	SQM	KGS	BOXES	SQM	KGS
60x60 . 24"x24" rett	2	0,72	30,60	32	23,04	996

Pezzi Speciali . Trims. Pièces Spéciales. Formstücke. Специальные изделия

Pezzi Speciali . Trims. Pièces Spéciales. Formstücke. Специальные изделия



Step Molato R11  
33x100 . 13"x40" rett ● B56  
1070972 Studio Peltro  
1070973 Studio Perla  
1070974 Studio Sabbia  
1070975 Studio Terracotta  
1070976 Studio Verderame



Step Torato R11  
33x100 . 13"x40" rett ● B57  
1070977 Studio Peltro  
1070978 Studio Perla  
1070979 Studio Sabbia  
1070980 Studio Terracotta  
1070981 Studio Verderame



Elemento ad "L" Assemblato R11  
15x100x5 . 6"x40"x2" rett ● B54  
1070901 Studio Peltro  
1070902 Studio Perla  
1070903 Studio Sabbia  
1070904 Studio Terracotta  
1070905 Studio Verderame



Gradone Costa Retta R11  
35x100x5 . 13 3/4"x40"x2" rett ● B60  
1070906 Studio Peltro  
1070907 Studio Perla  
1070908 Studio Sabbia  
1070909 Studio Terracotta  
1070910 Studio Verderame



Step Molato R11  
30x60 . 12"x24" rett ● B36  
1070870 Studio Peltro  
1070871 Studio Perla  
1070872 Studio Sabbia  
1070873 Studio Terracotta  
1070874 Studio Verderame



Step Torato R11  
30x60 . 12"x24" rett ● B37  
1070875 Studio Peltro  
1070876 Studio Perla  
1070877 Studio Sabbia  
1070878 Studio Terracotta  
1070879 Studio Verderame



Elemento ad "L" Assemblato R11  
15x60x5 . 6"x24"x2" rett ● B43  
1070880 Studio Peltro  
1070881 Studio Perla  
1070882 Studio Sabbia  
1070883 Studio Terracotta  
1070884 Studio Verderame



Gradone Costa Retta R11  
35x60x5 . 13 3/4"x24"x2" rett ● B52  
1070886 Studio Peltro  
1070887 Studio Perla  
1070888 Studio Sabbia  
1070889 Studio Terracotta  
1070890 Studio Verderame



Griglia per Piscina R11  
20x60 . 8"x24" rett ● B56  
1070891 Studio Peltro  
1070892 Studio Perla  
1070893 Studio Sabbia  
1070894 Studio Terracotta  
1070895 Studio Verderame



Coppia Angolo Griglia (2 pz) R11  
20x60 . 8"x24" rett ● B63B  
1070896 Studio Peltro  
1070897 Studio Perla  
1070898 Studio Sabbia  
1070899 Studio Terracotta  
1070900 Studio Verderame

# 19mm dove?

WHERE? OÙ? WO? ГДЕ?



## 19 MILLIMETRI PER LA CASA

19 millimeters for the home | 19 mm pour la maison  
19 mm für die wohnung | 19 миллиметров для дома

### IN GIARDINO.

In the garden. Dans le jardin.  
Im Garten. В саду.

### NEL PATIO E NELLE TERRAZZE.

In the patio and terraces. Sous le porche et sur les terrasses.  
Im Innenhof und auf Terrassen. На patio или на террасах.

### NELLE SCALE E NEI VIALETTI.

In the stairways and walkways. Sur les escaliers et dans les ruelle.  
Auf Treppen und Wegen. На лестницах и на аллеях.

### IN PISCINA.

In the swimming pool. En piscine.  
Im Schwimmbad. В бассейне.



## 19 MILLIMETRI NEGLI SPAZI PUBBLICI

19 millimeters for public spaces | 19 mm dans les espaces publics  
19 mm in öffentlichen bereichen | 19 миллиметров в общественных пространствах

### NEI RISTORANTI E HOTEL.

In the hospitality. Dans les restaurants et dans les hôtels.  
In Gästebereichen. В гостиничных заведениях.

### NEGLI STABILIMENTI BALNEARI.

In the bathing establishments. Dans les établissements balnéaires.  
In Badeanstalten. На пляжах.

### NELLE AREE COMMERCIALI.

In the commercial areas. Dans les zones commerciales.  
In Gewerbebereichen. В коммерческих зонах.

### NEI CAMMINAMENTI E NELL'ARREDO URBANO.

In the walkways and urban environment. Dans la passerelle et dans la décoration urbaine.  
Auf Gehwegen und in Stadtbereichen. На дорожках и в городском благоустройстве.

# 19mm come?

HOW? COMMENT? WIE? KAK?

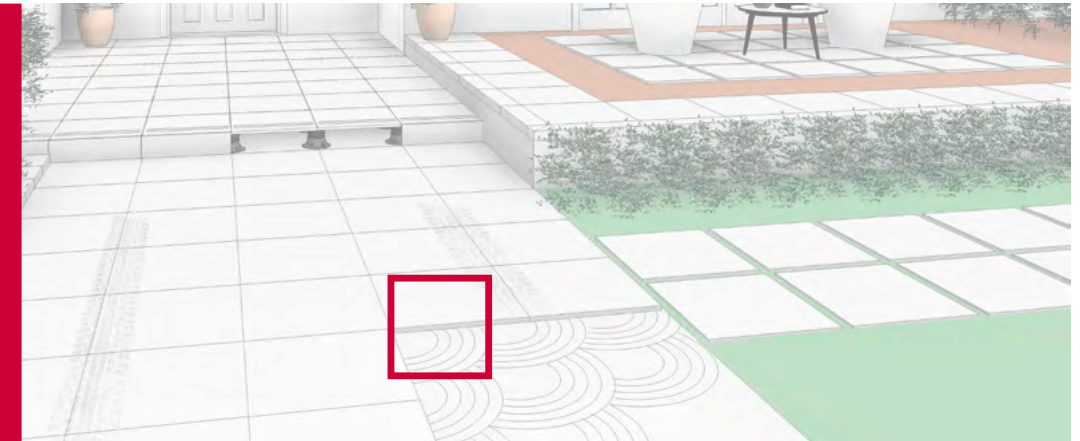

## POSA A COLLA SU MASSETTO

LAYING WITH GLUE FOR CARRIAGEABLE PATH.  
POSE À LA COLLE SUR CHAPE CARROSSABLE.  
VERLEGUNG MIT KLEBER.  
ТРАДИЦИОННАЯ УКЛАДКА НА КЛЕЙ



All'interno di aree urbane, la posa su massetto rappresenta la scelta ottimale per realizzare zone di parcheggio, marciapiedi, percorsi pedonali e ciclabili, garantendo al tempo stesso praticità, pulizia, estetica e sicurezza.

In urban areas, laying on concrete beds is the best choice to create parking areas, sidewalks, footpaths and cycle tracks, guaranteeing a result that is practical, clean, beautiful and safe all at the same time.

En zone urbaine, la pose sur chape est un choix optimal pour réaliser des aires de stationnement, des trottoirs, des parcours piétons et cyclables, garantissant à la fois praticité, propreté, esthétique et sécurité.

Die traditionelle Verlegung erlaubt eine maximale Nutzung der hohen Bruchfestigkeit und eignet sich ideal für die Gestaltung befahrbarer Bodenbeläge. Die Oberfläche nimmt keinen Schmutz auf und absorbiert keine Flecken und ist daher extrem reinigungsfreundlich.

В городских зонах укладка на стяжку является оптимальным выбором для строительства стоянок, тротуаров, пешеходных и велосипедных дорожек, гарантируя практичность, чистоту, эстетику и безопасность.

# 19mm perchè?

WHY? POURQUOI? WARUM? ПОЧЕМУ?

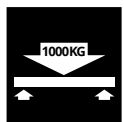

### PERCHÈ RESISTE ALLA FLESSIONE E ALLA FORZA DI ROTTURA

Modulus of rupture and breaking strength  
Résistant à la flexion et à la force de rupture  
Biegefestigkeit und Bruchlast  
прочная на изгиб и устойчивая к разрушающим усилиям



### PERCHÈ RESISTE AI CARICHI DI ROTTURA CON SUPPORTO

Charge of rupture with support  
Résistant aux charges de rupture avec support  
Biegefestigkeit und Bruchlast  
устойчивая к разрушающим усилиям с основой

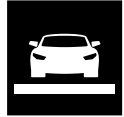

### PERCHÈ È CARRABILE

Drive-over  
Carrossable  
Befahrbar  
допускает движение транспортных средств



### PERCHÈ È FACILE DA POSARE ED È RETTIFICATO

Easy to fit and it is rectified  
Parce qu'il est facile à poser  
Leicht verlegen und rektifiziert  
легко укладывается, обрезная



### PERCHÈ È COORDINABILE INDOOR/OUTDOOR

Because it can match indoor and outdoor  
Parce qu'il coordonne l'intérieur/extérieur  
Weil er für Innen- und Außenbereiche koordinierbar ist  
потому, что интерьер и экстерьер сочетаются друг с другом



### PERCHÈ È FACILE DA PULIRE

Easy to clean  
Facile à nettoyer  
Pflegeleicht  
легко чистится



### PERCHÈ È REMOVIBILE E ISPEZIONABILE

Because it can be removed and inspected  
Facile à enlever et à contrôler  
Weil er entfernbar und inspektionierbar ist  
потому, что он съемный и осматриваемый



### PERCHÈ È IGNIFUGO

Resistant to fire  
Ignifuge  
Feuerbeständig  
огнестойкая и негорючая



### PERCHÈ RESISTE ALLA SCIVOLOSITÀ

Skid resistance  
Antidérapant  
Rutschfestigkeit  
Сопротивление скольжению



### PERCHÈ RESISTE ALLA MUFFA, AL MUSCHIO E AL SALE

Resistant to mold, moss and salt  
Résistant à la moisissure, à la mousse et au sel  
Resistent gegen Schimmel, Moos und Salz  
Устойчива к плесени, мху и соли



### PERCHÈ RESISTE AI COLORI E ALLA LUCE

Color resistance to light  
Aucune altération des couleurs à la lumière  
Lichtbeständigkeit  
Устойчива к краске и свету



### PERCHÈ RESISTE AL GELO

Frost resistance  
Résistant au gel  
Frostbeständigkeit  
Морозостойкая



### PERCHÈ RESISTE ALLO SHOCK TERMICO

Thermal shock resistance  
Résistant au choc thermique  
Temperaturwechselbeständigkeit  
Устойчива к тепловым перепадам



### PERCHÈ NON ASSORBE ACQUA

No water absorption  
Aucune absorption d'eau  
Keine Wasseraufnahme  
Водонепроницаема



### PERCHÈ RESISTE ALL'ATTACCO CHIMICO

Resistance to chemical attack  
Résistance à l'attaque chimique  
Säure- und Laugenbeständigkeit  
Устойчива к бытовым химикатам

# 19 come? mm

HOW? COMMENT? WIE? KAK?

# 2

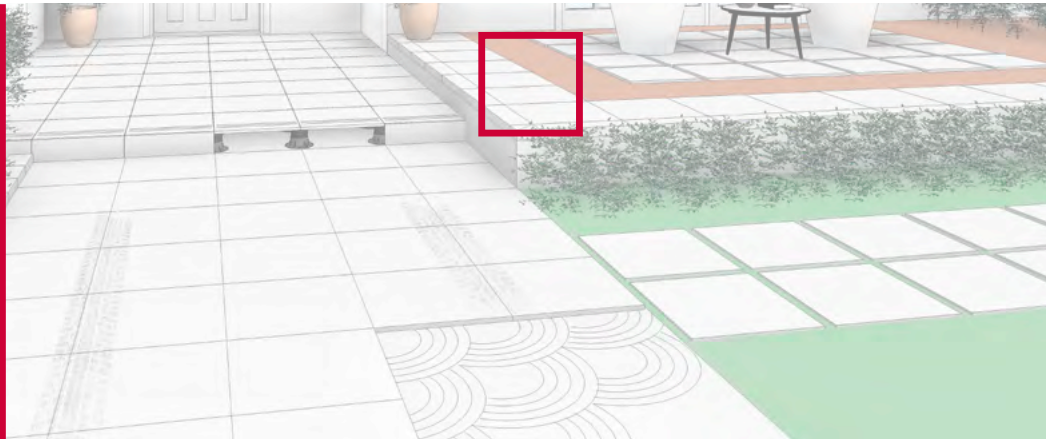

## FLOTTANTE SU SABBIA E GHIAIA

DRY INSTALLATION ONTO GRAVEL OR SAND.  
POSE À SEC SUR GRAVIER OU SABLE.  
TROCKENVERLEGUNG IN SPLITT ODER  
AUF SANDBETT  
СУХАЯ УКЛАДКА НА  
ПЕСОК ИЛИ ЩЕБЕНЬ.

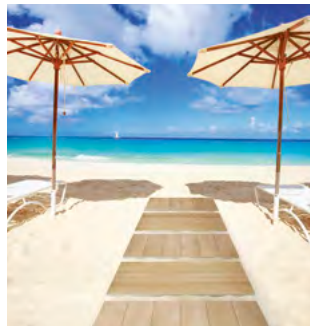

Per creare camminamenti pedonali, percorsi di raccordo e aree di sosta, è possibile posare il materiale direttamente su ghiaia o sabbia. I differenti metodi di posa consentono di realizzare ambienti articolati e garantire uniformità visiva anche in presenza di sottofondi diversi.

To create pedestrian walkways, linking paths and waiting areas, the material can be laid directly onto gravel or sand. The different laying methods allow complex surroundings to be created and the visual uniformity to be guaranteed even with different underlayers.

Pour créer des allées piétonnes, des parcours de raccordement et des aires de stationnement, le matériau peut être posé directement sur sable ou gravier. Les différents modes de pose permettent de réaliser des espaces structurés et garantissent l'uniformité visuelle, même en présence de supports différents.

Für die Gestaltung von Gehwegen, Verbindungsstrecken und Aufenthaltsbereichen besteht die Möglichkeit, das Material direkt auf Kies oder Sand zu verlegen. Die unterschiedlichen Verlegungsmethoden erlauben die Einrichtung artikulierter Bereiche und garantieren auch bei verschiedenartigen Untergründen eine gleichmäßige Optik.

Для строительства пешеходных дорожек, выездов и стоянок материал можно укладывать непосредственно на щебень или песок. Различные методы укладки позволяют использовать плиты в разных условиях и гарантировать зрительную однородность даже при наличии разнотипных основ.

# 19 come? mm

HOW? COMMENT? WIE? KAK?

# 3

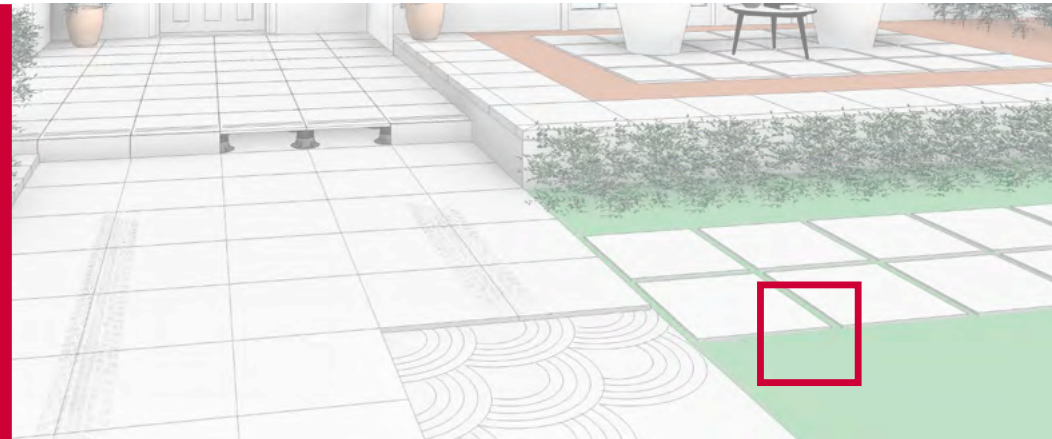

## FLOTTANTE SU TERRA

DRY INSTALLATION ONTO GRASS.  
POSE À SEC SUR GAZON.  
TROCKENVERLEGUNG AUF RASEN.  
СУХАЯ УКЛАДКА НА ТРАВУ.

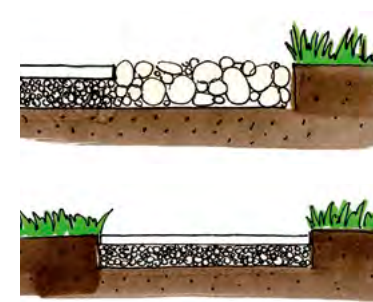

Con la posa a secco su erba si possono creare percorsi che si inseriscono con eleganza all'interno di parchi pubblici e giardini privati. Questa tecnica di posa è semplice, ecologica e non richiede l'intervento di personale professionista.

With dry laying on grass, you can create paths that blend elegantly into public parks and private gardens. This laying technique is simple, environmentally friendly, and does not require the intervention of professional operators.

La pose à sec sur gazon permet de créer des parcours qui s'insèrent avec élégance dans les parcs publics et les jardins privés. Simple et écologique, cette technique de pose ne requiert pas l'intervention d'un professionnel.

Durch Trockenverlegung auf Gras lassen sich Strecken gestalten, die sich elegant in öffentliche Parkanlagen wie auch Privatgärten fügen. Diese Verlegungstechnik ist einfach, ökologisch und verlangt kein Fachpersonal.

Благодаря сухой укладке на траву можно создавать такие дорожки, которые элегантно впишутся в городские парки и частные сады. Эта техника укладки является простой, экологичной, не требующей услуг специализированного персонала.

# 19 come?

## mm

HOW? COMMENT? WIE? KAK?

# 4



## FLOTTANTE SOPRAELEVATA E DRENANTE

INSTALLATION USING A DRAINING RAISED STRUCTURE.  
POSE SURÉLEVÉE ET DRAINANTE.  
DOPPELBODENVERLEGUNG AUF STELZLAGERN MIT DRAINAGE.  
УКЛАДКА ФАЛЬШПОЛОВ С ДРЕНАЖОМ.

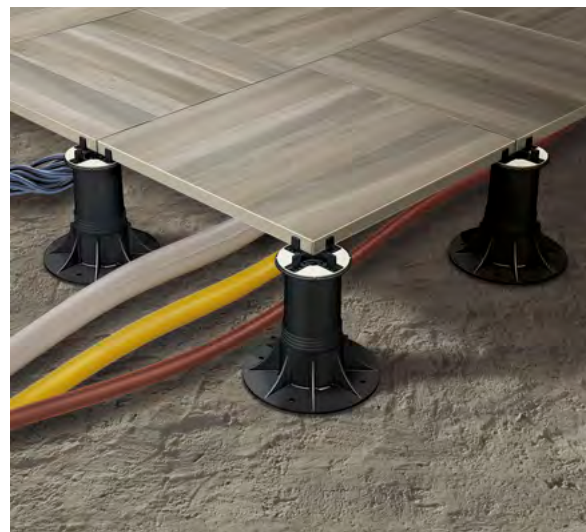
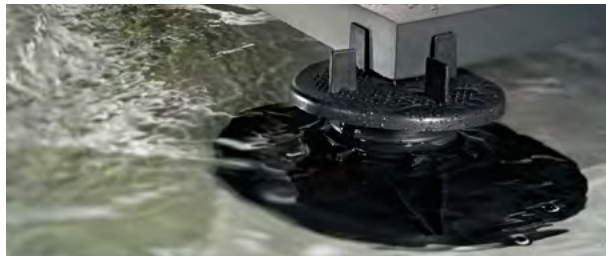

La posa sopraelevata è ottimale per ogni necessità di pavimentazione in presenza di cavi o tubi non inseriti nel massetto e per ogni necessità di ispezionabilità degli stessi o del sottofondo, inoltre garantisce il drenaggio delle acque piovane nelle pavimentazioni esterne.

Raised laying is excellent whenever there is a need for flooring with the cables or pipes not inserted in the bed and where these, or the underlayer, need to be accessed for inspection; it also guarantees the draining of rainwater in outdoor flooring.

La pose surélevée est un choix optimal pour la réalisation de revêtements de sol en présence de câbles ou de conduites hors chape. Elle laisse la possibilité d'inspecter ces derniers ou le support, et garantit le drainage des eaux de pluie dans les sols extérieurs.

Die Doppelbodenverlegung ist eine optimale Lösung für jede Bodengestaltung wo Kabel oder Rohrleitungen nicht in den Estrich eingebettet sind und wo Kabel, Rohrleitungen oder Untergründe inspektionierbar bleiben müssen. Außerdem garantieren Doppelböden bei externen Bodenbelägen die Regenwasserdrainage.

Фальшпол отлично подходит для любых необходимостей настила полов при наличии кабелей или труб, которые не включены в стяжку, а также для любых необходимостей осмотра как их самих, так и основы. Кроме того, гарантируется дренаж дождевой воды на наружных полах.

### PERCHÈ CONSENTE IL PASSAGGIO DI IMPIANTI ELETTRICI E IDRICI.

Because it allows the passage of electrical and plumbing installations. Parce qu'il permet le passage des équipements électriques et d'eau. Weil er die Durchführung von Strom- und Wasseranlagen erlaubt. Потому, что позволяет прокладывать электрические и водопроводные системы.

### PERCHÈ GARANTISCE IL DRENAGGIO DELLE ACQUE PIOVANE.

Because it allows stormwater drainage. Parce qu'il garantit le drainage de l'eau de pluie. Garantiert die Ableitung des Regenwassers. Потому, что он гарантирует дренаж дождевой воды.

### PERCHÈ RISOLVE PROBLEMI DI DISLIVELLO.

Because it solves floor unevenness. Parce qu'il résout les problèmes de dénivellation. Weil er bei Höhenunterschieden eine Lösung ist. Потому, что решает проблемы перепада уровня.

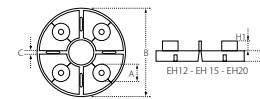

**SUPPORTO FISSO (EH)**  
Fixed support (EH)  
Support fixe (EH)  
Feste tragstruktur (EH)  
фиксированная опора (EH)  
EH12= h 12 mm € 0,50 pz

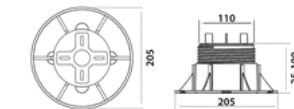

**SUPPORTO REGOLABILE (NM)**  
Adjustable support (NM)  
Support réglable (NM)  
Verstellbare tragstruktur (NM)  
регулируемая опора (NM)  
NM1= h 25/40 mm € 5,00 pz  
NM2= h 40/70 mm € 5,80 pz  
NM3= h 60/100 mm € 6,60 pz

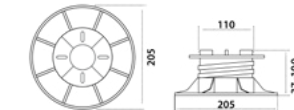

**SUPPORTO AUTOLIVELLANTE (SE)**  
Self-levelling support (SE)  
Support autonivelant (SE)  
Selbthnivellierende tragstruktur (SE)  
самовыравнивающаяся опора (SE)  
SE1= h 37/50 mm € 8,50 pz  
SE2= h 50/75 mm € 8,90 pz  
SE3= h 75/120 mm € 9,40 pz  
SE4= h 120/170 mm € 10,40 pz

### PERCHÈ È FACILE DA POSARE.

Because it is easy to lay down. Parce qu'il est facile à poser. Weil er leicht zu verlegen ist. Потому, что он прост в укладке.

### PERCHÈ È REMOVIBILE.

Because it is removable. Parce qu'il est amovible. Weil er entfernbar ist. Потому, что он съемный и осматриваемый.

### PERCHÈ È ISPEZIONABILE FACILMENTE.

Because it can be easily inspected. Parce qu'il est facile à vérifier. Weil er einfach inspektionierbar ist. Потому, что он легко осматривается.

### PERCHÈ È RIUTILIZZABILE.

Because it is reusable. Parce qu'il est réutilisable. Weil er wiederverwendbar ist. Потому, что он подлежит повторному использованию.

### CARATTERISTICHE TECNICHE SUPPORTI

Support technical features. Caracteristiques techniques support. Technische eigenschaften tragstruktur. технические характеристики опор.



#### SUPPORTI REALIZZATI CON MATERIALE TOTALMENTE RICICLABILE

Supports made with totally recycled material. Supports réalisés avec matériel entièrement recyclable. Stelzlager aus recycelbarem Material. Подставка полностью реализована из вторичного сырья.



#### RESISTENTI ALLE SOLUZIONI ACIDE E BASICHE

Resistant to acidic and basic solutions. Résistant aux solutions acides et basiques. Saeure- und Laugenbeständig. Устойчива к кислотным и щелочным растворам.



#### RESISTENTE AGLI AGENTI ATMOSFERICI

Weather resistant. Résistant à la désagrégation. Wetterbeständig. Устойчива к атмосферным факторам.



#### RESISTENTE A TEMPERATURE DA -30° A +120°

Temperature resistant from -30° to +120°. Résistant à la temperature de -30° à +120°. Beständigkeit beim Temperaturschwankungen von -30° bis +120°. Устойчива к перепадам температур от -30° до +120°.

PER UNA MIGLIORE STABILITÀ DELLA PAVIMENTAZIONE SOPRAELEVATA, SI SUGGERISCE L'IMPIEGO DI:

9 SUPPORTI PER LASTRA 100x100 cm  
5 SUPPORTI PER LASTRA 60x60 cm

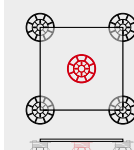

For more stability in the raised floor, the use of five supports per 60x60-24"x24" and nine supports per 100x100-40"x40" is advisable.

Pour une meilleure stabilité du sol surelevé, il est recommandé d'utiliser cinq plots pour la dalle en format 60x60 et neuf plots pour la dalle en format 100x100.

Für eine bessere Stabilität des Doppelbodens, wird die Verwendung von 5 Stelzlager für das Format 60x60 und 9 Stelzlager für das Format 100x100 empfohlen.

Для наилучшей устойчивости фальшполов рекомендуется использование пяти опор под плиту 60x60 и девяти опор под плиту 100x100.

7 SUPPORTI PER LASTRA 60x120 CM

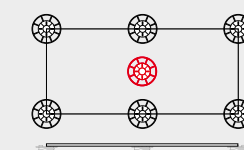

For more stability of the dry laid raised floor, the use of 7 supports per 60x120-24"x48" pavers is advisable.

Pour une meilleure stabilité du revêtement de sol surélevé posé à sec, il est recommandé d'utiliser 7 supports par dalle 60x120.

Zur Erhöhung der Stabilität von Doppelböden wird empfohlen, pro Platte im Format 60x120 7 Halter einzusetzen.

Для наилучшей устойчивости фальшполов рекомендуется использование опор в количестве 7 шт для формата 60x120 под каждую плиту.



# SCHEMI DI POSA\*

Laying sketch. Schémas de pose. Modulverlegungsbeispiele. Варианты Укладки.

MODULARE 1	
1 - 15,8x15,8	4,5%
2 - 15,8x31,7	9%
3 - 31,7x31,7	18%
4 - 31,7x48	27,2%
5 - 48x48	41,3%

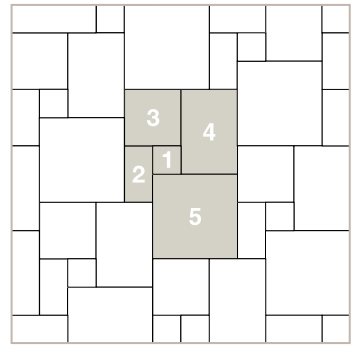

QUINTANA ■ A8

MODULARE 2	
1 - 15,8x15,8	2,7%
2 - 15,8x31,7	11%
3 - 31,7x31,7	11%
4 - 31,7x48	50%
5 - 48x48	25,3%

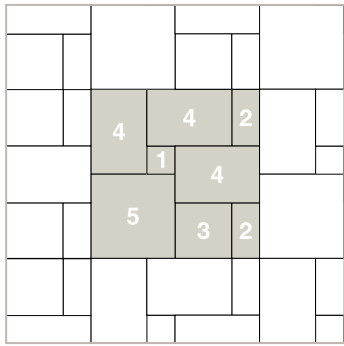

QUINTANA ■ A8

MODULARE 4	
1 - 15,8x15,8	7,6%
2 - 15,8x31,7	15,3%
3 - 31,7x31,7	30,7%
4 - 31,7x48	46,4%

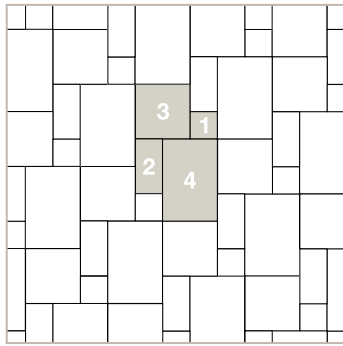

QUINTANA ■ A7

MODULARE 6	
1 - 15,8x15,8	4,9%
2 - 31,7x31,7	19,8%
3 - 31,7x48	30%
4 - 48x48	45,3%

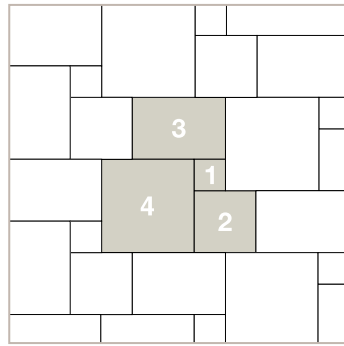

QUINTANA ■ A9

MODULARE 10			
1 - 20x20	14,3%	1 - 15,8x15,8	14,22%
2 - 20x40	28,6%	2 - 15,8x31,7	28,53%
3 - 40x40	57,1%	3 - 31,7x31,7	57,25%

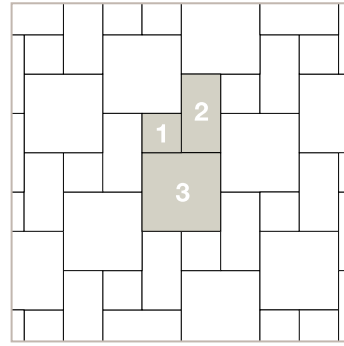
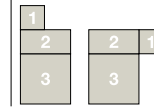

DUOMO ■ A8  
MAGISTRA ■ A8  
QUINTANA ■ A5  
RIABITA IL COTTO ■ A8

MODULARE 15	
1 - 31,7x31,7	28,24%
2 - 15,8x15,8	7,02%
3 - 48x48	64,74%

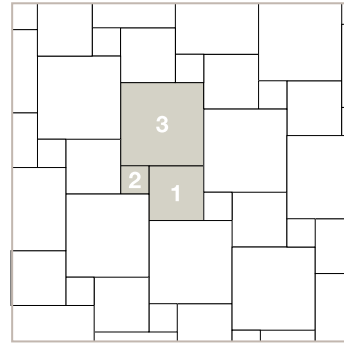

QUINTANA ■ A5

MODULARE 19	
1 - 20x20	11,1%
2 - 20x40	44,45%
3 - 40x40	44,45%

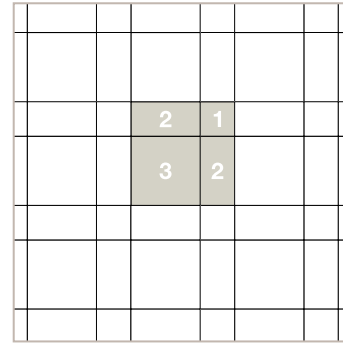

DUOMO ■ A8  
MAGISTRA ■ A8  
RIABITA IL COTTO ■ A8

MODULARE 26	
1 - 20x40	14,3%
2 - 40x40	28,6%
3 - 40x80	57,1%

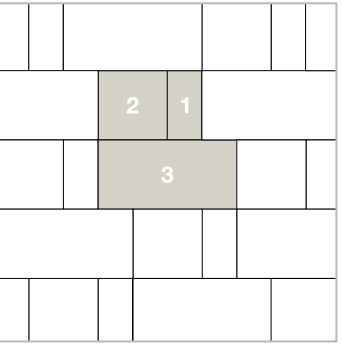

DUOMO ■ A12  
RIABITA IL COTTO ■ A12

MODULARE 27	
1 - 20x20	6,67%
2 - 20x40	13,34%
3 - 40x40	26,66%
4 - 40x80	53,33%

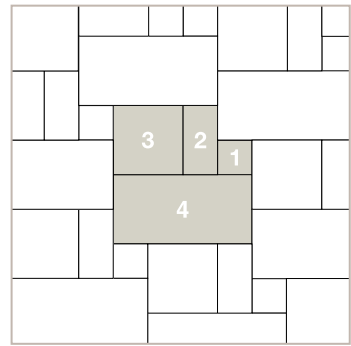

DUOMO ■ A12  
RIABITA IL COTTO ■ A12

MODULARE 30	
1 - 30x120	60%
2 - 20x120	40%

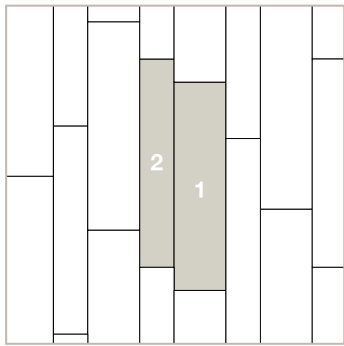

ÀCANTO ■ A34  
NEWPORT ■ A34  
NORWAY ■ A34

MODULARE 39	
1 - 20x20	11,1%
2 - 20x40	11,1%
3 - 40x40	44,4%
4 - 40x60,8	33,4%

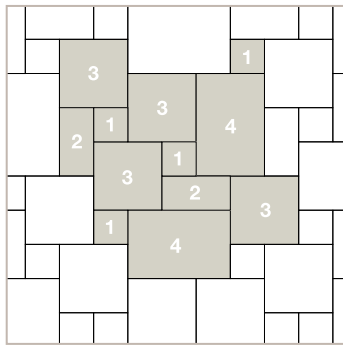

MAGISTRA ■ A10

MODULARE 40	
1 - 30x60	14,3%
2 - 60x60	28,5%
3 - 60x120	57,2%

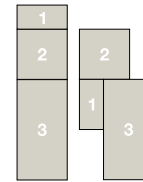
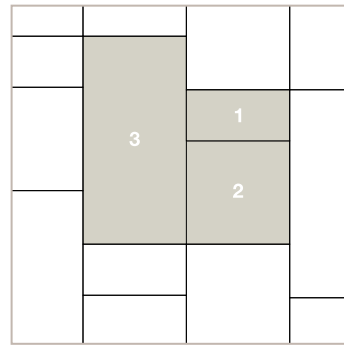

COSTRUIRE ■ A23  
EVOCA ■ A23  
FOSSIL RETT ■ A23  
PROMENADE ■ A23  
STUDIO 50 ■ A23

\* La posa modulare è consigliata con una fuga di 5 mm, 2 mm per i prodotti rettificati.

We recommend modular laying with a 5 mm 3/16" joint, and a 2 mm joint for rectified products.



La pose modulaire est conseillée avec un joint de 5 mm, 2 mm pour les produits réctifiés.

Die Modulverlegung wird mit einer Mindestfuge von 5 mm empfohlen, 2 mm fuer rektifizierte Produkte.

При модульной укладке рекомендуется шов в 5 мм, 2 мм для укладки модулем ректифицированной плитки.

# NOTE TECNICHE PEZZI SPECIALI

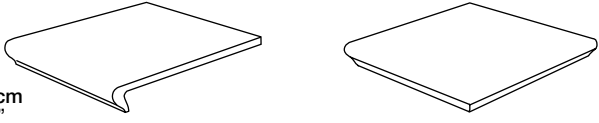
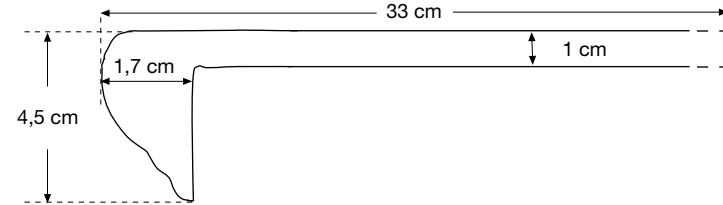
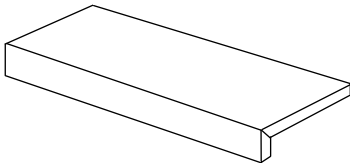
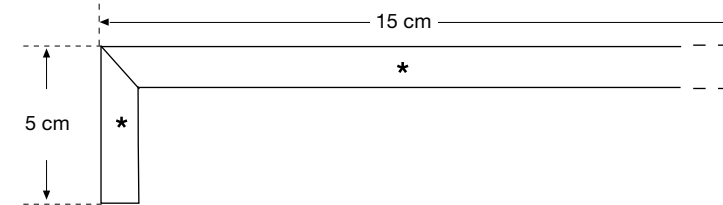
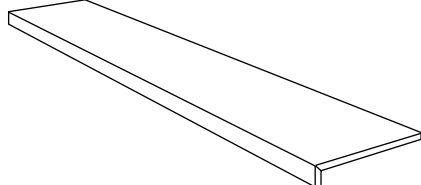
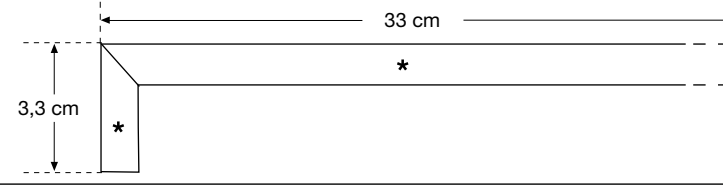
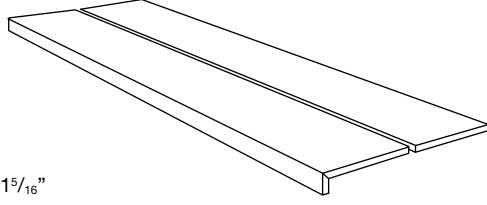
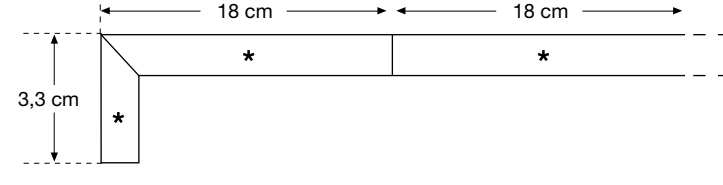
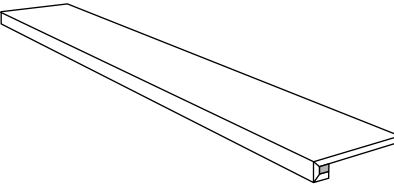
Trims Technical notes . Notes techniques concernant les pièces spéciales . Technische Hinweise zu den Formteile

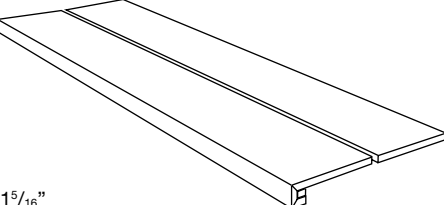
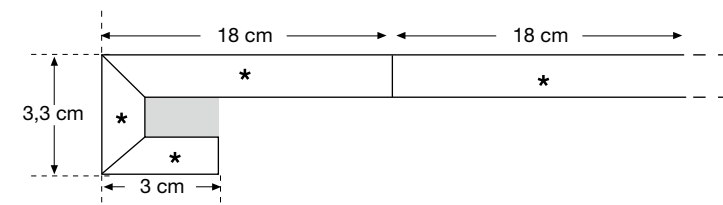
<b>GRADONE/ANGOLARE CON FRONTALE MONOLITICO - MONOLITHIC STEP TREAD / CORNER</b> <b>MARCHE/ANGLE AVEC LE DEVANT DE LA PIÈCE MONOLITHIQUE - STUFE/ECK-STUFE ALS EINZELSTÜCK</b>	
 <p>30x33 cm 12"x13" 33x33 cm 13"x13"</p>	
<b>ELEMENTO "L" ASSEMBLATO - ASSEMBLED L-SHAPED ELEMENT - ÉLÉMENT EN L ASSEMBLÉ</b> <b>ZUSAMMENSETZTS L-FÖRMIGES ELEMENT</b>	
 <p>15x60,8x5 cm 6"x24"x2"</p>	
<b>COSTA RETTA</b>	
 <p>30x120x3,3 cm 12"x48"x1<sup>5</sup>/<sub>16</sub>" 30x60x3,3 cm 12"x24"x1<sup>5</sup>/<sub>16</sub>"</p>	
<b>COSTA RETTA COMP. 2 PZ</b>	
 <p>36x118x3,3cm 14<sup>3</sup>/<sub>16</sub>"x46<sup>7</sup>/<sub>16</sub>"x1<sup>5</sup>/<sub>16</sub>"</p>	
<b>GRADONE SQUARE ASSEMBLATO - ASSEMBLED SQUARE STAIR - MARCHE SQUARE ASSEMBLÉ</b> <b>ZUSAMMENSETZTS STUFE SQUARE</b>	
 <p>30x120x3,3 cm 12"x48"x1<sup>5</sup>/<sub>16</sub>"</p>	
<b>GRADONE SQUARE ASSEMBLATO COMP. 2 PZ - ASSEMBLED SQUARE STAIR - MARCHE SQUARE ASSEMBLÉ</b> <b>ZUSAMMENSETZTS STUFE SQUARE</b>	
 <p>36x118x3,3cm 14<sup>3</sup>/<sub>16</sub>"x46<sup>7</sup>/<sub>16</sub>"x1<sup>5</sup>/<sub>16</sub>"</p>	

\* Spessore piastrella - Tile Thickness - Epaisseur du carreau - Stärke der Fliese

# NOTE TECNICHE PEZZI SPECIALI 19 MM

Trims Technical notes . Notes techniques concernant les pièces spéciales . Technische Hinweise zu den Formteile

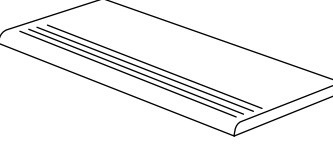
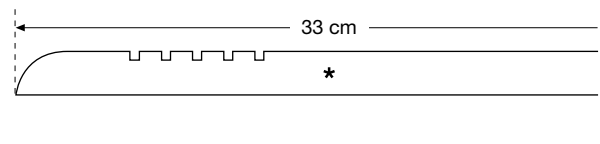
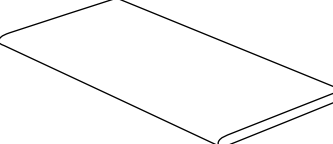
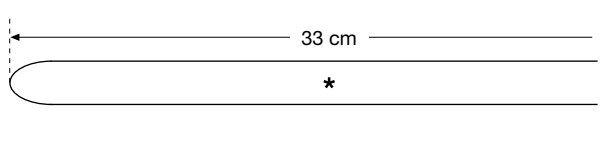
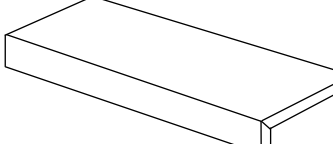
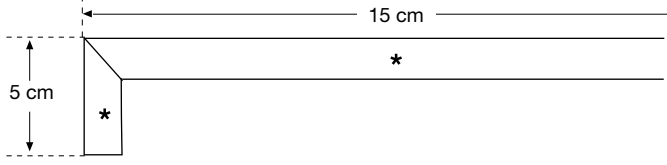
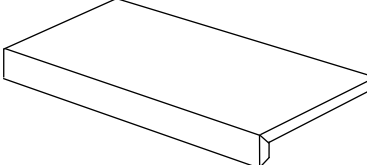
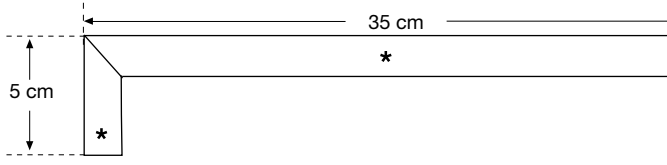
<b>STEP MOLATO</b>	
 <p>30x60 cm 12"x24" 30x120 cm 12"x48" 33x100 cm 13"x40"</p>	
<b>STEP TORATO</b>	
 <p>30x60 cm 12"x24" 30x120 cm 12"x48" 33x100 cm 13"x40"</p>	
<b>ELEMENTO "L" ASSEMBLATO - ASSEMBLED L-SHAPED ELEMENT - ÉLÉMENT EN L ASSEMBLÉ</b> <b>ZUSAMMENSETZTS L-FÖRMIGES ELEMENT</b>	
 <p>15x60x5 cm 6"x24"x2" 15x100x5 cm 6"x40"x2"</p>	
<b>COSTA RETTA</b>	
 <p>35x60x5 cm 13<sup>3</sup>/<sub>4</sub>"x24"x2" 35x100x5 cm 13<sup>3</sup>/<sub>4</sub>"x40"x2"</p>	

\* Spessore piastrella - Tile Thickness - Epaisseur du carreau - Stärke der Fliese

245

# CARATTERISTICHE TECNICHE

Technical characteristics. Caractéristiques techniques. Technische daten. Технические характеристики.

Costruire  
GRES PORCELLANATO A TUTTA MASSA. FULL BODY PORCELAIN STONEWARE. GRÈS CÉRAME PLAINE MASSE.  
VOLLMASSEFEINSTEINZEUG KERAMOGRAHIT PO VSEJ TOLŠČINE



GRES FINE PORCELLANATO SMALTATO. GLAZED FINE PORCELAIN STONEWARE. GRÈS CÉRAME FIN ÉMAILLÉ. GLASIERTES FEINSTEINZEUG. ТОЛКОГО ГЛАЗУРОВАННОГО ФАРФОРОВОГО КЕРАМОГРАНИТА

	Proprietà fisico-chimiche / Physical chemical properties / Propriétés physico chimiques Physisch chemische Eigenschaften / Физико химические свойства	Metodo di prova Standard of test / Norme du test / Testnorm / Метод испытания	Acanto	Canalgrande	Charwood	Costruire	Ducato di Borgogna	Duomo
	Dimensioni Dimensions Abmessungen Размеры							
	Aspetto superficiale Surface appearance Aspect superficiel Oberflächenbeschaffenheit Вид поверхности		≥ 95%	≥ 95%	≥ 95%	≥ 95%	≥ 95%	≥ 95%
	Lunghezza e larghezza Length and width Longueur et largeur Länge und Breite Длина и ширина	<b>W</b> <b>10 test</b>	± 0,3% max ± 1,5 mm	± 0,3% max ± 1,5 mm	± 0,5% max ± 2 mm	± 0,5% ± 2 mm	± 0,5% max ± 2 mm	± 0,5% max ± 2 mm
	Spessore Thickness Épaisseur Stärke Толщина		± 5% ± 0,5 mm	± 5% ± 0,5 mm	± 5% ± 0,5 mm	± 5% ± 0,5 mm	± 5% ± 0,5 mm	± 5% ± 0,5 mm
	Rettilineità degli spigoli Straightness of sides Rectitude des arrêtes Kantengeradheit Прямолинейность кромок		± 0,3% max ± 1,5 mm	± 0,3% max ± 1,5 mm	± 0,5% max ± 1,5 mm	± 0,3% ± 1,5 mm	± 0,5% max ± 2 mm	± 0,5% max ± 1,5 mm
	Ortogonalità Rectangularity Orthogonalité Rechtwinkligkeit Ортогональность		± 0,3% max ± 1,5 mm	± 0,3% max ± 1,5 mm	± 0,3% max ± 1,5 mm	± 0,3% ± 1,5 mm	± 0,3% max ± 2 mm	± 0,3% max ± 1,5 mm
Planarità Surface flatness Planéité Ebenflächigkeit Плоскостность	ISO 10545-2 ASTM C 485 Warpage diagonal/edge	± 0,3% max ± 1,5 mm ± 0,4%	± 0,3% max ± 1,5 mm ± 0,4%	± 0,3% max ± 1,5 mm ± 0,4%	± 0,3% max ± 1,5 mm ± 0,4%	± 0,3% max ± 2 mm ± 0,4%	± 0,3% max ± 1,5 mm ± 0,4%	
	Variazioni di tono Shade variations Variations de nuance Tonvariationen Вариация оттенка							
	Assorbimento d'acqua Water absorption Absorption d'eau Wasseraufnahme Водопоглощение	ISO 10545 - 3	E ≤ 0,3 % Bla GL	E ≤ 0,3 % Bla GL	E ≤ 0,3 % Bla GL	E ≤ 0,1 % Bla UGL	E ≤ 0,3 % Bla GL	E ≤ 0,3 % Bla GL
	Resistenza al gelo Frost resistance Résistance au gel Frostbeständigkeit Морозостойкость	ISO 10545 - 12	Resistente Resistant Résistant Widerstandsfähig Устойчивый	Resistente Resistant Résistant Widerstandsfähig Устойчивый	Resistente Resistant Résistant Widerstandsfähig Устойчивый	Resistente Resistant Résistant Widerstandsfähig Устойчивый	Resistente Resistant Résistant Widerstandsfähig Устойчивый	Resistente Resistant Résistant Widerstandsfähig Устойчивый
	Resistenza agli sbalzi termici Resistance to thermal shock Résistance aux écarts de température Temperaturwechselbeständigkeit Стойкость к тепловым перепадам	ISO 10545 - 9	Resistente Resistant Résistant Widerstandsfähig Устойчивый	Resistente Resistant Résistant Widerstandsfähig Устойчивый	Resistente Resistant Résistant Widerstandsfähig Устойчивый	-	Resistente Resistant Résistant Widerstandsfähig Устойчивый	Resistente Resistant Résistant Widerstandsfähig Устойчивый
	Resistenza al cavillo di piastrelle smaltate Crazing resistance of glazed tiles Résistance à la tréaillure des carreaux émaillés Haarrißbeständigkeit der glasierten Fliesen Стойкость глазурованной плитки к кракелюру	ISO 10545 - 11	Resistente Resistant Résistant Widerstandsfähig Устойчивый	Resistente Resistant Résistant Widerstandsfähig Устойчивый	Resistente Resistant Résistant Widerstandsfähig Устойчивый	-	Resistente Resistant Résistant Widerstandsfähig Устойчивый	Resistente Resistant Résistant Widerstandsfähig Устойчивый
	Resistenza della superficie (scala MOHS) Scratch hardness (MOHS scale) Dureté de la surface (échelle MOHS) Oberflächenhärte (MOHS skala) Поверхностная прочность по (шкале Мооса)	EN 101	MOHS ≥ 6	MOHS ≥ 6	MOHS ≥ 6	MOHS ≥ 6	MOHS ≥ 6	MOHS ≥ 6
	Resistenza alla abrasione della superficie di piastrelle smaltate Resistance to surface abrasion of glazed tiles Résistance à l'abrasion de la surface des carreaux émaillés Widerstand gegen Abrieb der Oberfläche der glasierten Fliesen Стойкость глазурованной плитки к поверхностному истиранию	ISO 10545 - 7	Classe 4 Class 4 Classe 4 Gruppe 4 Класс 4	Classe 5 Class 5 Classe 5 Gruppe 5 Класс 5	Classe 4 Class 4 Classe 4 Gruppe 4 Класс 4	-	Classe 4 Class 4 Classe 4 Gruppe 4 Класс 4	Classe 4 Class 4 Classe 4 Gruppe 4 Класс 4
	Resistenza all'abrasione profonda Abrasion resistance Résistance à l'abrasion Verschleiß (Volumenverlust) Сопротивление глубокому истиранию	UNI EN ISO 10545-6	-	-	-	≤ 175 mm³	-	-
	Resistenza ai prodotti chimici di uso domestico Resistance to household chemicals Résistance aux produits chimiques ménagers Widerstand gegen Haushaltsreinerger Стойкость к бытовым химикатам	ISO 10545 - 13	Classe A Class A Classe A Gruppe A Класс A	Classe A Class A Classe A Gruppe A Класс A	Classe A Class A Classe A Gruppe A Класс A	Classe A Class A Classe A Gruppe A Класс A	Classe A Class A Classe A Gruppe A Класс A	Classe A Class A Classe A Gruppe A Класс A
	Resistenza agli acidi e alle basi a bassa concentrazione Resistance to low concentrations of acids and bases Résistance aux acides et aux bases à faible concentration Widerstand gegen schwach konzentrierten Säuren und Laugen Стойкость к низкоконцентрированным кислотам и щелочам	ISO 10545 - 13	Classe LA - HA Class LA - HA Classe LA - HA Gruppe LA - HA Класс LA - HA	Classe LA - HA Class LA - HA Classe LA - HA Gruppe LA - HA Класс LA - HA	Classe LA - HA Class LA - HA Classe LA - HA Gruppe LA - HA Класс LA - HA	Classe LA - HA Class LA - HA Classe LA - HA Gruppe LA - HA Класс LA - HA	Classe LA - HA Class LA - HA Classe LA - HA Gruppe LA - HA Класс LA - HA	Classe LA - HA Class LA - HA Classe LA - HA Gruppe LA - HA Класс LA - HA
	Resistenza alle macchie di piastrelle smaltate Resistance to stains of glazed tiles Résistance aux taches des carreaux émaillés Widerstand gegen Fleckenbildner der glasierten Fliesen Стойкость глазурованной плитки к образованию пятен	ISO 10545 - 14	Classe 5 Class 5 Classe 5 Gruppe 5 Класс 5	Classe 5 Class 5 Classe 5 Gruppe 5 Класс 5	Classe 5 Class 5 Classe 5 Gruppe 5 Класс 5	Classe 5 Class 5 Classe 5 Gruppe 5 Класс 5	Classe 5 Class 5 Classe 5 Gruppe 5 Класс 5	Classe 5 Class 5 Classe 5 Gruppe 5 Класс 5
	Resistenza alla flessione Bending strength Résistance à la flexion Biegezugfestigkeit Прочность на изгиб	Modulo di rottura - Modulus of rupture Module de rupture - Bruchmodul - Модуль жесткости Carico di rottura - Breaking of rupture Charge de rupture - Bruchkraft - нагрузка	ISO 10545 - 4	R ≥ 35 N/mm² S ≥ 1300 N	R ≥ 35 N/mm² S ≥ 1300 N	R ≥ 35 N/mm² S ≥ 1300 N	R ≥ 35 N/mm² S ≥ 1300 N	R ≥ 35 N/mm² S ≥ 1300 N
	Caratteristiche antiscivolo / Coefficiente d'attrito statico Anti-slip properties / Static coefficient of friction Caractéristiques antidérapantes / Coefficient de frottement statique Rutschhemmende Eigenschaft / Statischer Reibungskoeffizient Характеристики устойчивости к скольжению / Коэффициент статического трения	DIN 51130 (no lux/lapp)	R 10	R 9	R 10	R 10	R 10	R 10
		B.C.R.A.REP.CEC.6/81 (no lux/lapp)	0,40 ≤ P ≤ 0,74	0,40 ≤ P ≤ 0,74	0,40 ≤ P ≤ 0,74	0,40 ≤ P ≤ 0,74	0,40 ≤ P ≤ 0,74	0,40 ≤ P ≤ 0,74
		DIN 51097 (no lux/lapp)	Classe B Class B Classe B Gruppe B Класс B	Classe A Class A Classe A Gruppe A Класс A	Classe A Class A Classe A Gruppe A Класс A	Classe B Class B Classe B Gruppe B Класс B	Classe B Class B Classe B Gruppe B Класс B	Classe B Class B Classe B Gruppe B Класс B
		DCOF Acu Test (no lux/lapp)	P ≥ 0,42	P ≥ 0,42	-	P ≥ 0,42	P ≥ 0,42	
		Pendulum Australiano AS 4586	-	-	-	-	-	
		Pendulum Britannico BS 7976	-	-	PTV > 36 wet	-	-	

GRES FINE PORCELLANATO SMALTATO. GLAZED FINE PORCELAIN STONWARE. GRÈS CÉRAME FIN ÉMAILLÉ. GLASIERTES FEINSTEINZEUG. ТОЛКОГО ГЛАЗУРОВАННОГО ФАРФОРОВОГО КЕРАМОГРАНИТА

	Proprietà fisico-chimiche / Physical chemical properties / Propriétés physico chimiques Physisch chemische Eigenschaften / Физико химические свойства	Metodo di prova Standard of test / Norme du test / Testnorm / Метод испытания	Evoca	Fossil	Gemme	I Travertini	Le Plance	
	Dimensioni Dimensions Dimensions Abmessungen Размеры				LUX-RETT	RETT		
	Aspetto superficiale Surface appearance Aspect superficiel Oberflächenbeschaffenheit Вид поверхности		≥ 95%	≥ 95%	≥ 95%	≥ 95%	≥ 95%	
	Lunghezza e larghezza Length and width Longueur et largeur Länge und Breite Длина и ширина	<b>W</b>  10 test	± 0,5% ± 2 mm ± 0,5% ± 2 mm	± 0,5% ± 2 mm ± 0,5% ± 2 mm	± 0,5% ± 2 mm ± 0,5% ± 2 mm	± 0,5% ± 2 mm ± 0,5% ± 2 mm	± 0,3% max ± 1,5 mm ± 0,3% max ± 1,5 mm	± 0,5% max ± 2 mm ± 0,5% max ± 2 mm
	Spessore Thickness Épaisseur Stärke Толщина	ISO 10545 - 2	± 5% ± 0,5 mm	± 5% ± 0,5 mm	± 5% ± 0,6 mm	± 5% ± 0,5 mm	± 5% ± 0,5 mm	± 5% ± 0,5 mm
	Rettilineità degli spigoli Straightness of sides Rectitude des arrêtes Kantengeradheit Прямолинейность кромок		± 0,3% ± 1,5 mm	± 0,3% ± 1,5 mm	± 0,3% ± 1,5 mm	± 0,3% ± 1,5 mm	± 0,3% max ± 1,5 mm	± 0,5% max ± 1,5 mm
	Ortogonalità Rectangularity Orthogonalité Rechtwinkligkeit Ортогональность		± 0,3% ± 1,5 mm	± 0,3% ± 1,5 mm	± 0,3% ± 1,5 mm	± 0,3% ± 1,5 mm	± 0,3% max ± 1,5 mm	± 0,5% max ± 2 mm
Planarità Surface flatness Planéité Ebenflächigkeit Плоскостность	ISO 10545-2 ASTM C 485 Warpage diagonal/edge	± 0,3% ± 1,5 mm ± 0,4%	± 0,3% ± 1,5 mm ± 0,4%	± 0,3% ± 1,5 mm ± 0,4%	± 0,3% ± 1,5 mm ± 0,4%	± 0,3% max ± 1,5 mm ± 0,4%	± 0,5% max ± 2 mm ± 0,4%	
 Variazioni di tono Shade variations Variations de nuance Tonvariationen Вариация оттенка		 MODERATA VARIAZIONE MODERATE VARIATION VARIATION MODERÉE MODERATE ABWEICHUNG МЯГКОЕ ОТКЛОНЕНИЕ		 LIEVE VARIAZIONE LIGHT VARIATION LEGERE VARIATION LEGERE ABWEICHUNG ЛЕГКОЕ ОТКЛОНЕНИЕ	 LIEVE VARIAZIONE LIGHT VARIATION LEGERE VARIATION LEGERE ABWEICHUNG ЛЕГКОЕ ОТКЛОНЕНИЕ	 LIEVE VARIAZIONE LIGHT VARIATION LEGERE VARIATION LEGERE ABWEICHUNG ЛЕГКОЕ ОТКЛОНЕНИЕ	 LIEVE VARIAZIONE LIGHT VARIATION LEGERE VARIATION LEGERE ABWEICHUNG ЛЕГКОЕ ОТКЛОНЕНИЕ	
 Assorbimento d'acqua Water absorption Absorption d'eau Wasseraufnahme Водопоглощение	ISO 10545 - 3	E ≤ 0,3 % Bla GL	E ≤ 0,3 % Bla GL	E ≤ 0,3 % Bla GL	E ≤ 0,3 % Bla GL	E ≤ 0,3 % Bla GL	E ≤ 0,3 % Bla GL	
 Resistenza al gelo Frost resistance Résistance au gel Frostbeständigkeit Морозостойкость	ISO 10545 - 12	Resistente Resistant Résistant Widerstandsfähig Устойчивый	Resistente Resistant Résistant Widerstandsfähig Устойчивый	Resistente Resistant Résistant Widerstandsfähig Устойчивый	Resistente Resistant Résistant Widerstandsfähig Устойчивый	Resistente Resistant Résistant Widerstandsfähig Устойчивый	Resistente Resistant Résistant Widerstandsfähig Устойчивый	
 Resistenza agli sbalzi termici Resistance to thermal shock Résistance aux écarts de température Temperaturwechselbeständigkeit Стойкость к тепловым перепадам	ISO 10545 - 9	-	-	Resistente Resistant Résistant Widerstandsfähig Устойчивый	Resistente Resistant Résistant Widerstandsfähig Устойчивый	Resistente Resistant Résistant Widerstandsfähig Устойчивый	Resistente Resistant Résistant Widerstandsfähig Устойчивый	
 Resistenza al cavillo di piastrelle smaltate Crazing resistance of glazed tiles Résistance à la tré sailure des carreaux émaillés Haarrißbeständigkeit der glasierten Fliesen Стойкость глазурованной плитки к кракелюру	ISO 10545 - 11	-	-	Resistente Resistant Résistant Widerstandsfähig Устойчивый	Resistente Resistant Résistant Widerstandsfähig Устойчивый	Resistente Resistant Résistant Widerstandsfähig Устойчивый	Resistente Resistant Résistant Widerstandsfähig Устойчивый	
 Resistenza della superficie (scala MOHS) Scratch hardness (MOHS scale) Dureté de la surface (échelle MOHS) Oberflächenhärte (MOHS skala) Поверхностная прочность по (шкале Мооса)	EN 101	MOHS ≥ 6	MOHS ≥ 6	MOHS ≥ 5	MOHS ≥ 6	MOHS ≥ 6	MOHS ≥ 6	
 Resistenza alla abrasione della superficie di piastrelle smaltate Resistance to surface abrasion of glazed tiles Résistance à l'abrasion de la surface des carreaux émaillés Widerstand gegen Abrieb der Oberfläche der glasierten Fliesen Стойкость глазурованной плитки к поверхностному истиранию	ISO 10545 - 7	Classe 4 Class 4 Classe 4 Gruppe 4 Класс 4	Classe 4 Class 4 Classe 4 Gruppe 4 Класс 4	BLACK MIRROR / FOSSENA Classe 3 Class 3 Classe 3 Gruppe 3 Класс 3	BLACK MIRROR / FOSSENA Classe 4 Class 4 Classe 4 Gruppe 4 Класс 4	BLACK MIRROR / FOSSENA Classe 3 Class 3 Classe 3 Gruppe 3 Класс 3	Classe 4 Class 4 Classe 4 Gruppe 4 Класс 4	
 Resistenza all'abrasione profonda Abrasion resistance Résistance à l'abrasion Verschleiß (Volumenverlust) Спротивление глубокому истиранию	UNI EN ISO 10545-6	-	-	-	-	-	-	
 Resistenza ai prodotti chimici di uso domestico Resistance to household chemicals Résistance aux produits chimiques ménagers Widerstand gegen Haushaltsreiniger Стойкость к бытовым химикатам	ISO 10545 - 13	Classe A Class A Classe A Gruppe A Класс A	Classe A Class A Classe A Gruppe A Класс A	Classe A Class A Classe A Gruppe A Класс A	Classe A Class A Classe A Gruppe A Класс A	Classe A Class A Classe A Gruppe A Класс A	Classe A Class A Classe A Gruppe A Класс A	
 Resistenza agli acidi e alle basi a bassa concentrazione Resistance to low concentrations of acids and bases Résistance aux acides et aux bases à faible concentration Widerstand gegen schwach konzentrierten Säuren und Laugen Стойкость к низкоконцентрированным кислотам и щелочам		Classe LA - HA Class LA - HA Classe LA - HA Gruppe LA - HA Класс LA - HA	Classe LA - HA Class LA - HA Classe LA - HA Gruppe LA - HA Класс LA - HA	Classe LA Class LA Classe LA Gruppe LA Класс LA	Classe LA - HA Class LA - HA Classe LA - HA Gruppe LA - HA Класс LA - HA	Classe LA - HA Class LA - HA Classe LA - HA Gruppe LA - HA Класс LA - HA	Classe LA - HA Class LA - HA Classe LA - HA Gruppe LA - HA Класс LA - HA	
 Resistenza alle macchie di piastrelle smaltate Resistance to stains of glazed tiles Résistance aux taches des carreaux émaillés Widerstand gegen Fleckenbildner der glasierten Fliesen Стойкость глазурованной плитки к образованию пятен	ISO 10545 - 14	Classe 5 Class 5 Classe 5 Gruppe 5 Класс 5	Classe 5 Class 5 Classe 5 Gruppe 5 Класс 5	Classe 5 Class 5 Classe 5 Gruppe 5 Класс 5	Classe 5 Class 5 Classe 5 Gruppe 5 Класс 5	Classe 5 Class 5 Classe 5 Gruppe 5 Класс 5	Classe 5 Class 5 Classe 5 Gruppe 5 Класс 5	
 Resistenza alla flessione Bending strength Résistance à la flexion Biegezugfestigkeit Прочность на изгиб	Modulo di rottura - Modulus of rupture Module de rupture - Bruchmodul - Модуль жесткости  Carico di rottura - Breaking of rupture Charge de rupture - Bruchkraft - нагрузка	ISO 10545 - 4	R ≥ 35 N/mm <sup>2</sup>  S ≥ 1300 N	R ≥ 35 N/mm <sup>2</sup>  S ≥ 1300 N	R ≥ 35 N/mm <sup>2</sup>  S ≥ 1300 N	R ≥ 35 N/mm <sup>2</sup>  S ≥ 1300 N	R ≥ 35 N/mm <sup>2</sup>  S ≥ 1300 N	
 Caratteristiche antiscivolo / Coefficiente d'attrito statico Anti-slip properties / Static coefficient of friction Caractéristiques antidérapantes / Coefficient de frottement statique Rutschhemmende Eigenschaft / Statischer Reibungskoeffizient Характеристики устойчивости к скольжению / Коэффициент статического трения	DIN 51130 (lux/lapp)	R 10	R 11	R 10	-	R 10	R 10 - R 9 lux	
	B.C.R.A.REP.CEC.6/81 (no lux/lapp)	0,40 ≤ P ≤ 0,74	P > 0,74	0,40 ≤ P ≤ 0,74	-	0,40 ≤ P ≤ 0,74	0,40 ≤ P ≤ 0,74	
	DIN 51097 (no lux/lapp)	Classe B Class B Classe B Gruppe B Класс B	Classe C Class C Classe C Gruppe C Класс C	Classe B Class B Classe B Gruppe B Класс B	-	Classe B Class B Classe B Gruppe B Класс B	Classe B Class B Classe B Gruppe B Класс B	
	DCOF Acu Test (no lux/lapp)	P ≥ 0,42	P ≥ 0,42	P ≥ 0,42	-	P ≥ 0,42	P ≥ 0,42	
	Pendulum Australiano AS 4586	Classe P2 Class P2 Classe P2 Gruppe P2 Класс P2	Classe P4 Class P4 Classe P4 Gruppe P4 Класс P4	-	-	-	-	
	Pendulum Britannico BS 7976	-	PTV > 36 wet	-	-	-	-	

GRES FINE PORCELLANATO SMALTATO. GLAZED FINE PORCELAIN STONWARE. GRÈS CÉRAME FIN ÉMAILLÉ. GLASIERTES FEINSTEINZEUG. ТОШКОГО ГЛАЗУРОВАННОГО ФАРФОРОВОГО КЕРАМОГРАНИТА

	Proprietà fisico-chimiche / Physical chemical properties / Propriétés physico chimiques / Physisch chemische Eigenschaften / Физико химические свойства	Metodo di prova / Standard of test / Norme du test / Testnorm / Метод испытания	Magistra	Metropolis	Newport 2.0	Norway	Pierre de France	Promenade			
	Dimensioni / Dimensions / Dimensionen / Abmessungen / Размеры		LUX	CLASSIC							
	Aspetto superficiale / Surface appearance / Aspect superficiel / Oberflächenbeschaffenheit / Вид поверхности		≥ 95%	≥ 95%	≥ 95%	≥ 95%	≥ 95%	≥ 95%			
	Lunghezza e larghezza / Length and width / Longueur et largeur / Länge und Breite / Длина и ширина	<b>W</b> 10 test	± 0,5% ± 2 mm	± 0,5% ± 2 mm	± 0,3% max ± 1,5 mm	± 0,3% max ± 1,5 mm	± 0,3% max ± 1,5 mm	± 0,3% max ± 1,5 mm	± 0,5% ± 2 mm		
	Spessore / Thickness / Épaisseur / Stärke / Толщина		± 0,5% ± 2 mm	± 0,5% ± 2 mm	± 0,3% max ± 1,5 mm	± 0,3% max ± 1,5 mm	± 0,3% max ± 1,5 mm	± 0,3% max ± 1,5 mm	± 0,5% ± 2 mm		
	Rettilineità degli spigoli / Straightness of sides / Rectitude des arrêtes / Kantengeradheit / Прямолинейность кромок		± 5% ± 0,5 mm	± 5% ± 0,5 mm	± 5% ± 0,5 mm	± 5% ± 0,5 mm	± 5% ± 0,5 mm	± 5% ± 0,5 mm	± 5% ± 0,5 mm		
	Ortogonalità / Rectangularity / Orthogonalité / Rechtwinkligkeit / Ортогональность		± 0,3% ± 1,5 mm	± 0,3% ± 1,5 mm	± 0,3% max ± 1,5 mm	± 0,3% max ± 1,5 mm	± 0,3% max ± 1,5 mm	± 0,3% max ± 1,5 mm	± 0,3% ± 1,5 mm		
Planarità / Surface flatness / Planéité / Ebenflächigkeit / Плоскостность		ISO 10545-2	± 0,3% ± 1,5 mm	± 0,3% ± 1,5 mm	± 0,3% max ± 1,5 mm	± 0,3% max ± 1,5 mm	± 0,3% max ± 1,5 mm	± 0,3% ± 1,5 mm			
		ASTM C 485 Warpage diagonal/edge	± 0,4%	± 0,4%	± 0,4%	± 0,4%	± 0,4%	± 0,4%			
	Variazioni di tono / Shade variations / Variations de nuance / Tonvariationen / Вариация оттенка										
	Assorbimento d'acqua / Water absorption / Absorption d'eau / Wasseraufnahme / Водопоглощение	ISO 10545 - 3	E ≤ 0,1 % Bla GL	E ≤ 0,1 % Bla GL	E ≤ 0,3 % Bla GL	E ≤ 0,3 % Bla GL	E ≤ 0,3 % Bla GL	E ≤ 0,1 % Bla GL			
	Resistenza al gelo / Frost resistance / Résistance au gel / Frostbeständigkeit / Морозостойкость	ISO 10545 - 12	Resistente / Résistant / Résistant / Widerstandsfähig / Устойчивый	Resistente / Résistant / Résistant / Widerstandsfähig / Устойчивый	Resistente / Résistant / Résistant / Widerstandsfähig / Устойчивый	Resistente / Résistant / Résistant / Widerstandsfähig / Устойчивый	Resistente / Résistant / Résistant / Widerstandsfähig / Устойчивый	Resistente / Résistant / Résistant / Widerstandsfähig / Устойчивый			
	Resistenza agli sbalzi termici / Resistance to thermal shock / Résistance aux écarts de température / Temperaturwechselbeständigkeit / Стойкость к тепловым перепадам	ISO 10545 - 9	Resistente / Résistant / Résistant / Widerstandsfähig / Устойчивый	Resistente / Résistant / Résistant / Widerstandsfähig / Устойчивый	Resistente / Résistant / Résistant / Widerstandsfähig / Устойчивый	Resistente / Résistant / Résistant / Widerstandsfähig / Устойчивый	Resistente / Résistant / Résistant / Widerstandsfähig / Устойчивый	Resistente / Résistant / Résistant / Widerstandsfähig / Устойчивый			
	Resistenza al cavillo di piastrelle smaltate / Cracking resistance of glazed tiles / Résistance à la tréaillure des carreaux émaillés / Haarrißbeständigkeit der glasierten Fliesen / Стойкость глазурованной плитки к кракелюру	ISO 10545 - 11	Resistente / Résistant / Résistant / Widerstandsfähig / Устойчивый	Resistente / Résistant / Résistant / Widerstandsfähig / Устойчивый	Resistente / Résistant / Résistant / Widerstandsfähig / Устойчивый	Resistente / Résistant / Résistant / Widerstandsfähig / Устойчивый	Resistente / Résistant / Résistant / Widerstandsfähig / Устойчивый	Resistente / Résistant / Résistant / Widerstandsfähig / Устойчивый			
	Resistenza della superficie (scala MOHS) / Scratch hardness (MOHS scale) / Dureté de la surface (échelle MOHS) / Oberflächenhärte (MOHS skala) / Поверхностная прочность по (шкале Мооса)	EN 101	MOHS ≥ 5	MOHS ≥ 6	MOHS ≥ 6	MOHS ≥ 6	MOHS ≥ 6	MOHS ≥ 6			
	Resistenza alla abrasione della superficie di piastrelle smaltate / Resistance to surface abrasion of glazed tiles / Résistance à l'abrasion de la surface des carreaux émaillés / Widerstand gegen Abrieb der Oberfläche der glasierten Fliesen / Стойкость глазурованной плитки к поверхностному истиранию	ISO 10545 - 7	Classe 4 / Class 4 / Classe 4 / Gruppe 4 / Класс 4	Classe 4 / Class 4 / Classe 4 / Gruppe 4 / Класс 4	Classe 4 / Class 4 / Classe 4 / Gruppe 4 / Класс 4	Classe 4 / Class 4 / Classe 4 / Gruppe 4 / Класс 4	Classe 4 / Class 4 / Classe 4 / Gruppe 4 / Класс 4	Ebano, Tan: Classe 3 / Class 3 / Classe 3 / Gruppe 3 / Класс 3 Argento, Corda, Sabbia: Classe 4 / Class 4 / Classe 4 / Gruppe 4 / Класс 4			
	Resistenza all'abrasione profonda / Abrasion resistance / Résistance à l'abrasion / Verschleiß (Volumenverlust) / Сопротивление глубокому истиранию	UNI EN ISO 10545-6	-	-	-	-	-	-			
	Resistenza ai prodotti chimici di uso domestico / Resistance to household chemicals / Résistance aux produits chimiques ménagers / Widerstand gegen Haushaltsreiner / Стойкость к бытовым химикатам	ISO 10545 - 13	Classe A / Class A / Classe A / Gruppe A / Класс A	Classe A / Class A / Classe A / Gruppe A / Класс A	Classe A / Class A / Classe A / Gruppe A / Класс A	Classe A / Class A / Classe A / Gruppe A / Класс A	Classe A / Class A / Classe A / Gruppe A / Класс A	Classe A / Class A / Classe A / Gruppe A / Класс A			
	Resistenza agli acidi e alle basi a bassa concentrazione / Resistance to low concentrations of acids and bases / Résistance aux acides et aux bases à faible concentration / Widerstand gegen schwach konzentrierten Säuren und Laugen / Стойкость к низкоконцентрированным кислотам и щелочам	ISO 10545 - 13	Classe LA / Class LA / Classe LA / Gruppe LA / Класс LA	Classe LA / Class LA / Classe LA / Gruppe LA / Класс LA	Classe LA - HA / Class LA - HA / Classe LA - HA / Gruppe LA - HA / Класс LA - HA	Classe LA - HA / Class LA - HA / Classe LA - HA / Gruppe LA - HA / Класс LA - HA	Classe LA - HA / Class LA - HA / Classe LA - HA / Gruppe LA - HA / Класс LA - HA	Classe LA - HA / Class LA - HA / Classe LA - HA / Gruppe LA - HA / Класс LA - HA			
	Resistenza alle macchie di piastrelle smaltate / Resistance to stains of glazed tiles / Résistance aux taches des carreaux émaillés / Widerstand gegen Fleckenbildner der glasierten Fliesen / Стойкость глазурованной плитки к образованию пятен	ISO 10545 - 14	Classe 5 / Class 5 / Classe 5 / Gruppe 5 / Класс 5	Classe 5 / Class 5 / Classe 5 / Gruppe 5 / Класс 5	Classe 5 / Class 5 / Classe 5 / Gruppe 5 / Класс 5	Classe 5 / Class 5 / Classe 5 / Gruppe 5 / Класс 5	Classe 5 / Class 5 / Classe 5 / Gruppe 5 / Класс 5	Classe 5 / Class 5 / Classe 5 / Gruppe 5 / Класс 5			
	Resistenza alla flessione / Bending strength / Résistance à la flexion / Biegezugfestigkeit / Прочность на изгиб	ISO 10545 - 4	Modulo di rottura - Modulus of rupture / Module de rupture - Bruchmodul - Модуль жесткости / Carico di rottura - Breaking of rupture / Bruchkraft - нагрузка	R ≥ 35 N/mm <sup>2</sup> S ≥ 1300 N	R ≥ 35 N/mm <sup>2</sup> S ≥ 1300 N	R ≥ 35 N/mm <sup>2</sup> S ≥ 1300 N	R ≥ 35 N/mm <sup>2</sup> S ≥ 1300 N	R ≥ 35 N/mm <sup>2</sup> S ≥ 1300 N			
	Caratteristiche antiscivolo / Coefficiente d'attrito statico / Anti-slip properties / Static coefficient of friction / Caractéristiques antidérapantes / Coefficient de frottement statique / Rutschhemmende Eigenschaft / Statischer Reibungskoeffizient / Характеристики устойчивости к скольжению / Коэффициент статического трения	DIN 51130 (lux/lapp)	-	R 10	R 10	R 9	R 10	R 10	R 10	R 11	
		B.C.R.A. REP. CEC. 6/81 (no lux/lapp)	-	0,40 ≤ P ≤ 0,74	0,40 ≤ P ≤ 0,74	0,40 ≤ P ≤ 0,74	0,40 ≤ P ≤ 0,74	0,40 ≤ P ≤ 0,74	0,40 ≤ P ≤ 0,74	0,40 ≤ P ≤ 0,74	
		DIN 51097 (no lux/lapp)	-	Classe B / Class B / Classe B / Gruppe B / Класс B	Classe C / Class C / Classe C / Gruppe C / Класс C	Classe C / Class C / Classe C / Gruppe C / Класс C	Classe B / Class B / Classe B / Gruppe B / Класс B	Classe C / Class C / Classe C / Gruppe C / Класс C	Classe B / Class B / Classe B / Gruppe B / Класс B	Classe C / Class C / Classe C / Gruppe C / Класс C	Classe C / Class C / Classe C / Gruppe C / Класс C
		DCOF Acu Test (no lux/lapp)	-	P ≥ 0,42	P ≥ 0,42	P ≥ 0,42	P ≥ 0,42	P ≥ 0,42	P ≥ 0,42	P ≥ 0,42	
		Pendulum Australiano AS 4586	-	Classe P4 / Class P4 / Classe P4 / Gruppe P4 / Класс P4	-	-	-	-	-	-	
Pendulum Britannico BS 7976	-	PTV > 36 wet	-	-	-	-	-	-			

GRES FINE PORCELLANATO SMALTATO. GLAZED FINE PORCELAIN STONWARE. GRÈS CÉRAME FIN ÉMAILLÉ. GLASIERTES FEINSTEINZEUG. ТОШКОГО ГЛАЗУРОВАННОГО ФАРФОРОВОГО КЕРАМОГРАНИТА

	Proprietà fisico-chimiche / Physical chemical properties / Propriétés physico chimiques / Physisch chemische Eigenschaften / Физико химические свойства	Metodo di prova / Standard of test / Norme du test / Testnorm / Метод испытания	Quintana	Riabita il Cotto	Studio 50	Tahoe	Urban	19MM		
	Dimensioni / Dimensions / Dimensionen / Abmessungen / Размеры	ISO 10545 - 2								
	Aspetto superficiale / Surface appearance / Aspect superficiel / Oberflächenbeschaffenheit / Вид поверхности		≥ 95%	≥ 95%	≥ 95%	≥ 95%	≥ 95%	≥ 95%		
	Lunghezza e larghezza / Length and width / Longueur et largeur / Länge und Breite / Длина и ширина		W 10 test	± 0,5% max ± 2 mm	± 0,5% max ± 2 mm	± 0,5% ± 2 mm	± 0,5% max ± 2 mm	± 0,5% max ± 2 mm	± 0,3% max ± 1,5 mm	
	Spessore / Thickness / Épaisseur / Stärke / Толщина			± 0,5% max ± 2 mm	± 0,5% max ± 2 mm	± 0,5% ± 2 mm	± 0,5% max ± 2 mm	± 0,5% max ± 2 mm	± 0,3% max ± 1,5 mm	
	Rettilineità degli spigoli / Straightness of sides / Rectitude des arrêtes / Kantengeradheit / Прямолинейность кромок			± 5% ± 0,5 mm	± 5% ± 0,5 mm	± 5% ± 0,5 mm	± 5% ± 0,5 mm	± 5% ± 0,5 mm	± 5% ± 0,5 mm	
	Ortogonalità / Rectangularity / Orthogonalité / Rechtwinkligkeit / Ортогональность			± 0,5% max ± 1,5 mm	± 0,5% max ± 1,5 mm	± 0,3% ± 1,5 mm	± 0,5% max ± 1,5 mm	± 0,5% max ± 1,5 mm	± 0,3% max ± 1,5 mm	
	Planarità / Surface flatness / Planéité / Ebenflächigkeit / Плоскостность	ISO 10545-2 ASTM C 485 Warpage diagonal/edge	± 0,3% max ± 1,5 mm	± 0,3% max ± 1,5 mm	± 0,3% ± 1,5 mm	± 0,3% max ± 1,5 mm	± 0,3% max ± 1,5 mm	± 0,3% max ± 1,5 mm		
			± 0,4%	± 0,4%	± 0,4%	± 0,4%	± 0,4%	± 0,4%		
	Variazioni di tono / Shade variations / Variations de nuance / Tonvariationen / Вариация оттенка							-		
	Assorbimento d'acqua / Water absorption / Absorption d'eau / Wasseraufnahme / Водопоглощение	ISO 10545 - 3	E ≤ 0,3 % Bla GL	E ≤ 0,3 % Bla GL	E ≤ 0,1 % Bla GL	E ≤ 0,3 % Bla GL	E ≤ 0,3 % Bla GL	E ≤ 0,1 % Bla GL		
	Resistenza al gelo / Frost resistance / Résistance au gel / Frostbeständigkeit / Морозостойкость	ISO 10545 - 12	Resistente / Résistant / Widerstandsfähig / Устойчивый	Resistente / Résistant / Widerstandsfähig / Устойчивый	Resistente / Résistant / Widerstandsfähig / Устойчивый	Resistente / Résistant / Widerstandsfähig / Устойчивый	Resistente / Résistant / Widerstandsfähig / Устойчивый	Resistente / Résistant / Widerstandsfähig / Устойчивый		
	Resistenza agli sbalzi termici / Resistance to thermal shock / Résistance aux écarts de température / Temperaturwechselbeständigkeit / Стойкость к тепловым перепадам	ISO 10545 - 9	Resistente / Résistant / Widerstandsfähig / Устойчивый	Resistente / Résistant / Widerstandsfähig / Устойчивый	Resistente / Résistant / Widerstandsfähig / Устойчивый	Resistente / Résistant / Widerstandsfähig / Устойчивый	Resistente / Résistant / Widerstandsfähig / Устойчивый	Resistente / Résistant / Widerstandsfähig / Устойчивый		
	Resistenza al cavillo di piastrelle smaltate / Cracking resistance of glazed tiles / Résistance à la tréaillure des carreaux émaillés / Haarrißbeständigkeit der glasierten Fliesen / Стойкость глазурованной плитки к кракелюру	ISO 10545 - 11	Resistente / Résistant / Widerstandsfähig / Устойчивый	Resistente / Résistant / Widerstandsfähig / Устойчивый	Resistente / Résistant / Widerstandsfähig / Устойчивый	Resistente / Résistant / Widerstandsfähig / Устойчивый	Resistente / Résistant / Widerstandsfähig / Устойчивый	Resistente / Résistant / Widerstandsfähig / Устойчивый		
	Resistenza della superficie (scala MOHS) / Scratch hardness (MOHS scale) / Dureté de la surface (échelle MOHS) / Oberflächenhärte (MOHS skala) / Поверхностная прочность по (шкале Мооса)	EN 101	MOHS ≥ 6	MOHS ≥ 6	MOHS ≥ 6	MOHS ≥ 6	MOHS ≥ 6	MOHS ≥ 6		
	Resistenza alla abrasione della superficie di piastrelle smaltate / Resistance to surface abrasion of glazed tiles / Résistance à l'abrasion de la surface des carreaux émaillés / Widerstand gegen Abrieb der Oberfläche der glasierten Fliesen / Стойкость глазурованной плитки к поверхностному истиранию	ISO 10545 - 7	Classe 4 / Class 4 / Classe 4 / Gruppe 4 / Класс 4	Classe 4 / Class 4 / Classe 4 / Gruppe 4 / Класс 4	Studio Corvino / Classe 4 / Class 4 / Classe 4 / Gruppe 4 / Класс 4 Studio Terracotta, Studio Peltro, Studio Verderame, Studio Perla, Studio Sabbia / Classe 4 / Class 4 / Classe 4 / Gruppe 4 / Класс 4	Classe 4 / Class 4 / Classe 4 / Gruppe 4 / Класс 4	Classe 4 / Class 4 / Classe 4 / Gruppe 4 / Класс 4	Classe 4 / Class 4 / Classe 4 / Gruppe 4 / Класс 4		
	Resistenza all'abrasione profonda / Abrasion resistance / Résistance à l'abrasion / Verschleiß (Volumenverlust) / Сопrotивление глубокому истиранию	UNI EN ISO 10545-6	-	-	-	-	-	-		
	Resistenza ai prodotti chimici di uso domestico / Resistance to household chemicals / Résistance aux produits chimiques ménagers / Widerstand gegen Haushaltsreiner / Стойкость к бытовым химикатам	ISO 10545 - 13	Classe A / Class A / Classe A / Gruppe A / Класс A	Classe A / Class A / Classe A / Gruppe A / Класс A	Classe A / Class A / Classe A / Gruppe A / Класс A	Classe A / Class A / Classe A / Gruppe A / Класс A	Classe GA / Class GA / Classe GA / Gruppe GA / Класс GA	Classe A / Class A / Classe A / Gruppe A / Класс A		
	Resistenza agli acidi e alle basi a bassa concentrazione / Resistance to low concentrations of acids and bases / Résistance aux acides et aux bases à faible concentration / Widerstand gegen schwach konzentrierten Säuren und Laugen / Стойкость к низкоконцентрированным кислотам и щелочам	ISO 10545 - 13	Classe LA - HA / Class LA - HA / Classe LA - HA / Gruppe LA - HA / Класс LA - HA	Classe LA - HA / Class LA - HA / Classe LA - HA / Gruppe LA - HA / Класс LA - HA	Classe LA - HA / Class LA - HA / Classe LA - HA / Gruppe LA - HA / Класс LA - HA	Classe LA - HA / Class LA - HA / Classe LA - HA / Gruppe LA - HA / Класс LA - HA	Classe GLA - GHA / Class GLA - GHA / Classe GLA - GHA / Gruppe GLA - GHA / Класс GLA - GHA	Classe LA - HA / Class LA - HA / Classe LA - HA / Gruppe LA - HA / Класс LA - HA		
	Resistenza alle macchie di piastrelle smaltate / Resistance to stains of glazed tiles / Résistance aux taches des carreaux émaillés / Widerstand gegen Fleckenbildner der glasierten Fliesen / Стойкость глазурованной плитки к образованию пятен	ISO 10545 - 14	Classe 5 / Class 5 / Classe 5 / Gruppe 5 / Класс 5	Classe 5 / Class 5 / Classe 5 / Gruppe 5 / Класс 5	Classe 5 / Class 5 / Classe 5 / Gruppe 5 / Класс 5	Classe 5 / Class 5 / Classe 5 / Gruppe 5 / Класс 5	Classe 5 / Class 5 / Classe 5 / Gruppe 5 / Класс 5	Classe 5 / Class 5 / Classe 5 / Gruppe 5 / Класс 5		
	Resistenza alla flessione / Bending strength / Résistance à la flexion / Biegezugfestigkeit / Прочность на изгиб	Modulo di rottura - Modulus of rupture / Module de rupture - Bruchmodul - Модуль жесткости Carico di rottura - Breaking of rupture / Charge de rupture - Bruchkraft - Çarпузка	ISO 10545 - 4	R ≥ 35 N/mm <sup>2</sup> S ≥ 1300 N	R ≥ 35 N/mm <sup>2</sup> S ≥ 1300 N	R ≥ 35 N/mm <sup>2</sup> S ≥ 1300 N	R ≥ 35 N/mm <sup>2</sup> S ≥ 1300 N	R ≥ 50 N/mm <sup>2</sup> S ≥ 5000 N		
	Caratteristiche antiscivolo / Coefficiente d'attrito statico / Anti-slip properties / Static coefficient of friction / Caractéristiques antidérapantes / Coefficient de frottement statique / Rutschhemmende Eigenschaft / Statischer Reibungskoeffizient / Характеристики устойчивости к скольжению / Коэффициент статического трения	DIN 51130 (lux/lapp)	R 10	R 10	R 10	R 10	R 10	R 11		
		B.C.R.A. REP. CEC. 6/81 (no lux/lapp)	-	0,20 ≤ f <sub>s</sub> ≤ 0,40	0,20 ≤ f <sub>s</sub> ≤ 0,40	0,40 ≤ f <sub>s</sub> ≤ 0,74	0,40 ≤ f <sub>s</sub> ≤ 0,74	0,40 ≤ f <sub>s</sub> ≤ 0,74	0,40 ≤ f <sub>s</sub> ≤ 0,74	
		DIN 51097 (no lux/lapp)	-	Classe B / Class B / Classe B / Gruppe B / Класс B	Classe C / Class C / Classe C / Gruppe C / Класс C	Classe B / Class B / Classe B / Gruppe B / Класс B	Classe C / Class C / Classe C / Gruppe C / Класс C	Classe C / Class C / Classe C / Gruppe C / Класс C	Classe C / Class C / Classe C / Gruppe C / Класс C	Classe C / Class C / Classe C / Gruppe C / Класс C
		DCOF Acu Test (no lux/lapp)	-	f <sub>s</sub> ≥ 0,42	f <sub>s</sub> ≥ 0,42	f <sub>s</sub> ≥ 0,42	f <sub>s</sub> ≥ 0,42	f <sub>s</sub> ≥ 0,42	f <sub>s</sub> ≥ 0,42	
		Pendulum Australiano AS 4586	-	-	-	-	-	-	-	
		Pendulum Britannico BS 7976	-	-	-	-	-	-	-	

252

253

# SUPERFICI

Surfaces . Surfaces . Oberflächen . Поверхности

Serenissima, nell'intento di fornire prodotti adeguati ad ogni tipo di ambiente, produce una vasta gamma di superfici in grado di rispondere ad ogni condizione e necessità d'impiego. Oltre alle superfici classiche, vengono prodotti pavimenti antiscivolo sia con la tecnica delle applicazioni superficiali di smalti adeguati, che tramite l'utilizzo di idonei stampi strutturati. Inoltre per ottemperare alla richiesta in tema estetico si forniscono prodotti lappati o con superfici che per loro natura creano disegni o forme esteticamente apprezzabili.

Serenissima is producing porcelain tiles with a wide range of surfaces studied on purpose for every use and condition, in order to be suitable for any kind of project. Beside standard surfaces, Serenissima is producing antislip surfaces using superficial and appropriate applications or using directly structure molds during production. In order to achieve high aesthetic requirements Serenissima offering also honed and special finishes that makes porcelain tiles extremely appealing and in line with current trends.

L'usine Serenissima, afin de fournir des produits appropriés à tous les niveaux d'application, réalise une grosse gamme de surfaces différentes capable de satisfaire toutes les nécessités d'emploi. En plus des surfaces classiques, nous réalisons des finitions anti-slip (ou antidérapantes) aussi bien avec l'application de traitements de produits appropriés qu'avec l'utilisation de moules structurés. Encore, afin d'enrichir le niveau esthétique de la gamme des produits et les choix disponibles, nous fournissons aussi des finitions polis et semi polis (ou adoucis).

Da sehr unterschiedliche Einsatzbereiche gibt, produzierten Serenissima mehrere Oberflächen. Es werden klassische Oberflächen und rutschfeste Oberflächen produziert, entweder mit rutschfesten Glasuren oder mit strukturierten Stempeln. Fuer aestetisch hoehe Ansprüche werden polierte oder angeschliffene Oberflächen angefertigt.

Стремясь поставить материал, подходящий для отделки любого типа помещений, Serenissima предлагают широкий ассортимент поверхностей плитки, способный удовлетворить самые разные условия и требования к использованию. Serenissima производят и классические поверхности, и противоскользящие полы, используя при этом, как технику нанесения специальных поверхностных эмалей, так и структурированные пресс-формы. Кроме того, для удовлетворения эстетических требований, изготавливается полированная и/или шлифованная продукция, а так же изделия с поверхностями, которые за счёт своих свойств образуют рисунки или формы с ценными эстетическими качествами.

# CARATTERISTICHE TECNICHE

Technical characteristics . Caractéristiques techniques . Technische daten . Технические характеристики.

## SCIVOLOSITA'

La resistenza allo scivolamento è una caratteristica che ricade su sicurezza e salute degli utilizzatori, ovviamente nel caso di pavimentazioni. Le superfici scivolose sono potenziali cause di infortuni, anche gravi sia in ambito civile che negli ambienti di lavoro. La grandezza che quantifica la resistenza allo scivolamento è il coefficiente di attrito (statico o dinamico), al quale è proporzionale la forza, parallela alla superficie di contatto, che occorre applicare perchè si abbia moto relativo tra due corpi, e quindi anche la forza che ne definisce le condizioni di equilibrio. Quanto più alto è il coefficiente di attrito, tanto minore è la scivolosità. Attualmente non è disponibile un metodo di misura standardizzato a livello internazionale, la maggior parte delle nazioni ha metodi propri derivati da leggi, disposizioni antinfortunistiche o altre regolamentazioni di carattere nazionale. Per aver un buon risultato, il valore medio del coefficiente di attrito dinamico deve essere:  $\mu > 0,40$ ,  $R \geq R9$  e  $\mu \geq A$ . Qui di seguito riportiamo la sintesi degli indicatori che misurano la resistenza alla scivolosità:

**R:** indica l'angolo di inclinazione raggiunto nel test di prova

**A.B.C.:** sono riferimenti di resistenza alla scivolosità relativa ad ambienti umidi e a piedi nudi.

**SLIP RESISTANCE** Slip resistance is a characteristic that affects the health and safety of users in the case of flooring. Slippery surfaces are potential causes of accidents, even serious ones, in civil and work environments. The value that measures slip resistance is the coefficient of friction (static or dynamic); the force required for the relative movement between two bodies (and therefore also the force defining the equilibrium condition), the said force being parallel to the contact surface, is proportional to the coefficient of friction. The higher the coefficient of friction, the less slippery is the surface. An international standardised measurement is not currently available and most countries have their own measurement methods based on laws, accident prevention regulations or other national regulations. For a good result, the average dynamic coefficient of friction should be:  $\mu > 0,40$ ,  $R \geq R9$  and  $\mu \geq A$ . Here below a short description of the indicators to measure slip-resistance:

**R:** angle of slope achieved during testing

**A.B.C.:** slip resistance indicators for walking in humid areas.

**GLISSANCE** La résistance à la glissance du carrelage est une caractéristique très importante pour la sécurité et la santé des utilisateurs et des professionnels pendant la pose du matériel. Les surfaces glissantes sont potentiellement cause d'accidents, même graves, dans le niveau civil comme professionnel. La grandeur qui quantifie la résistance au glissement est le coefficient de frottement (statique ou dynamique), qui est proportionnelle à la force, parallèle à la surface de contact, qui devrait être appliquée, car il ya du mouvement relatif entre les deux organes, et donc aussi la force qui définit les conditions d'équilibre. Plus le coefficient de frottement est grand, moins importante sera la glissance. Actuellement, il n'existe aucune méthode normalisée de mesure de niveau international, la plupart des nations ont leurs propres méthodes dérivées de lois, règles ou règlements de prévention de caractère national. Pour un bon résultat, la valeur moyenne du coefficient de frottement dynamique, devrait être:  $\mu > 0,40$ ,  $R \geq R9$  e  $\mu \geq A$ . Voici un résumé des indicateurs qui mesurent la résistance à la glisse:

**R:** indique l'angle d'inclination mesurée avec le test.

**A.B.C.:** sont des valeurs de résistance à la glisse relatives aux niveaux humides et à pieds nus.

**RUTSCHIGKEIT** Natürlich ist die Rutschfestigkeit eine Eigenschaft, die sich im Bereich der Bodenbeläge auf die Sicherheit und Gesundheit der Anwender auswirkt. Rutschige Oberflächen sind mögliche Ursachen für unter Umständen auch schwere Unfälle sowohl im zivilen Bereich als in der Arbeitsumgebung. Die Größe, die die Rutschfestigkeit misst, ist der Reibungskoeffizient (statisch und dynamisch). Zu diesen verhält sich die Kraft proportional, die parallel zur Kontaktfläche wirkt und angewandt werden muss, damit eine relative Bewegung zwischen zwei Körpern erfolgt. Somit ist sie auch die Kraft, die die Bedingungen für das Gleichgewicht bestimmt. Je höher der Reibungskoeffizient ist, umso niedriger ist die Rutschigkeit. Derzeit steht auf internationaler Ebene keine standardisierte Messmethode zur Verfügung. Der Großteil der Länder besitzt eigene Methoden, die auf Gesetzen, Unfallschutzbestimmungen oder anderen Regelungen nationaler Art beruhen. Um ein gutes Ergebnis zu erzielen, muss der durchschnittliche Wert des dynamischen Reibungskoeffizienten betragen:  $\mu > 0,40$ ,  $R \geq R9$  und  $\mu \geq A$ .

Nachfolgend führen wir eine Zusammenfassung der Indikatoren auf, mit denen die Rutschfestigkeit gemessen wird:

**R:** gibt den beim Test erreichten Neigungswinkel an

**A.B.C.:** sind Bezüge der Rutschfestigkeit hinsichtlich Feuchträume und Füße

**СОПРОТИВЛЕНИЕ СКОЛЬЖЕНИЮ** Устойчивость к скольжению - это характеристика, от которой зависит безопасность и здоровье потребителей, конечно, в случае, если речь идет о напольных покрытиях. Скользкие поверхности являются потенциальной причиной несчастных случаев, иногда также тяжелых, как в жилых, так и в промышленных помещениях. Величиной, определяющей устойчивость к скольжению, является коэффициент трения (статического или динамического), которому пропорциональна сила, параллельная контактной поверхности, которую необходимо приложить для получения относительного движения между двумя телами, и, следовательно, также сила, которая определяет условия их равновесия. Чем больше коэффициент трения, тем меньше способность к скольжению. В настоящее время не существует международного стандартного метода измерения этой величины, большинство государств использует свои собственные методы, исходя из положений законов, норм техники безопасности или других национальных нормативов. Для получения хорошего результата среднее значение коэффициента динамического скольжения должна составлять  $\mu > 0,40$ ,  $R \geq R9$  und  $\mu \geq A$ .

Ниже перечислены показатели, измеряющие устойчивость к скольжению:

**R:** означает уклон, полученный при тестировании во время испытаний

**A.B.C.:** показатели устойчивости к скольжению во влажных помещениях и при движении босыми ногами.

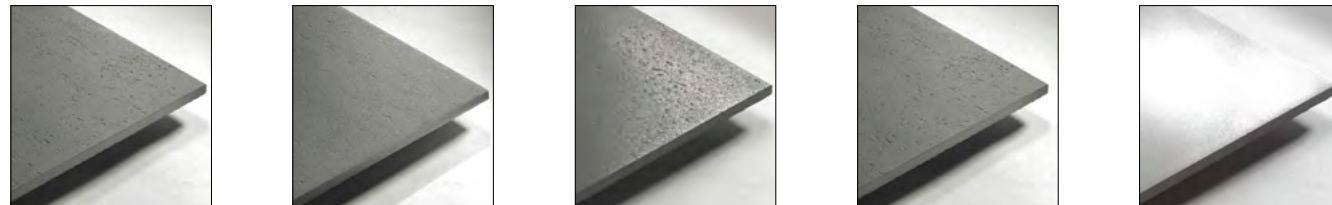
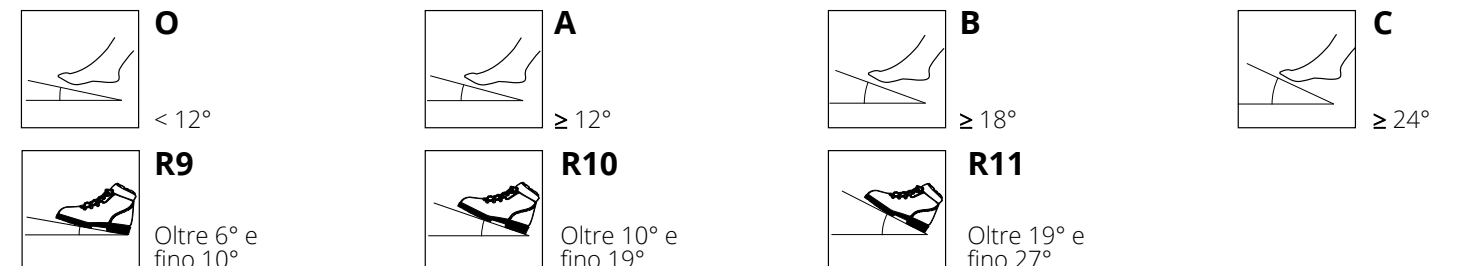

**SUPERFICIE NATURALE**      **SUPERFICIE NATURALE/RETTIFICATA R11**      **SUPERFICIE NATURALE LAPPATA**      **SUPERFICIE NATURALE RETTIFICATA**      **SUPERFICIE RETTIFICATA LUX/LAPPATA**

## VARIAZIONI DI TONO . Shade variations . Variations de nuance . Tonvariationen . Степень разнотонности

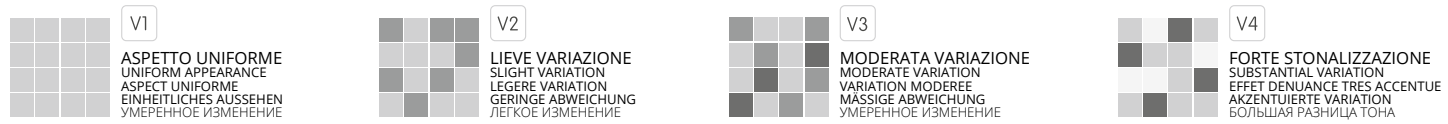





# LAYING AND CLEANING

Posa e pulizia . Pose et lavage . Verlegung und Reinigung

## LAYING SUGGESTIONS

The success of a porcelain stoneware floor by Serenissima is due to the technical and aesthetical features of the materials as well as to a combination of elements (bed, binding layer, expansion joints, etc.) which build up a real system. The laying operations, carried out in the correct sequence, are also as important as the choice of tiles. When choosing the most suitable adhesive and the application method refer to the instructions of the manufacturer. However, the designers has to establish the correct way of application of the tiles depending on the structure and the foreseen utilization of the floor. The design of all tiled surfaces should be entrusted to an expert designer, who must calculate the dimensions of the sub-base, the cement-based layers, the bedding layer, the falls and the entire laying system, taking into account the structure, the intended use of the spaces, the expected loads and the mechanical, thermal, physical and chemical stresses which will impact on the tiled surface. The designer must also determine in the laying specification every detail of the site, including type and method of laying , materials, particle size, mixing proportions, size of joints, location of structural, expansion and perimeter joints, etc.

## LAYING OPERATIONS

1. Carefully choose the aesthetic and technical requirements of the tiles (in relation to the style and intended use of the spaces), the tile formats to be used, the laying scheme, and the width and colour of the joints.
2. Laying edge-to-edge without joints is strongly discouraged, indeed it is not practicable for exterior applications. In the case of modular laying of different formats, allow the following joint widths:

2 mm <sup>m</sup>/<sub>16</sub> for rectified products;  
4 or 5 mm <sup>m</sup>/<sub>16</sub> or <sup>m</sup>/<sub>16</sub> for NON-rectified products.
3. Notification at time of ordering: always specify if the material requested is intended for multifformat laying to allow our sales office to send the client material with matching gauges and colouring.
4. Serenissima stoneware tiles may be laid with traditional mortar or with adhesive.
5. Carry out laying to a professional standard, following the instructions of the designer, the site manager and the laying specification.
6. For best management of the site, it is essential to pay careful attention to the working times of the materials used, and follow the manufacturer's instructions.
7. Check materials before they are laid-out. Claims on materials already installed will not be accepted.
8. Lay some pieces of product (at least 3 sqm) to check the overall effect. Lay the material taking it from several boxes and carefully check its size accuracy, shade and material sorting.
9. The high level of vitrification belonging to group Serenissima tiles bears modest caliber tolerances, therefore in the lay-out is advisable to leave at least 3 mm - 1/8” grout line between each tile.
10. Do not mark the upper part with pencils or felt pens.
11. Wait 48/72 hours before walking on the floor. A fine product laid in a bad way will not yield good aesthetic results.
12. When laying, you are recommended not to stagger the strips by more than 25% of the lenght.

## GUIDELINES FOR LAYING RECTIFIED MATERIALS

Installation of ground, closed-joint products requires the installer's full attention, with special reference to the level of the laying plane and to the continuity of the joints.

For optimal installation results, Serenissima recommends maintaining a joint at least of 2 mm - <sup>m</sup>/<sub>16</sub> for single format installations and combine mixed formats.

No joint setting, especially in large size product, is strongly advised against by all major adhesive producers for the following reasons:

- difficulty in withstanding possible structural movement due to lack of joint;
- different shrink/expand behaviour, in case of high thermal excursion;
- difficulty in obtaining an effective and long lasting grouting.

Serenissima does not recommend closed joint tiling and is not liable if this method is employed.

Serenissima recommends a minimum 2 mm - <sup>m</sup>/<sub>16</sub> joint when tiling with rectified edge tiles.

## GROUTING

1. If the cement and sand grout is not used, it is advisable to use grout with the same colour shades (it is preferable not to employ dark grout such as black, blue, red grout on light-coloured materials).
2. Fill the joints with grout only when the floor can safely be walked on, having first removed all kinds of residue from the joints.
3. Carry out grouting to a professional standard, following the instructions of the designer, the site manager and the laying specification.
4. Grout small surfaces at a time (4/5 sqm) and remove the exceeding amounts by means of sponges or wet cloths (with clean water only) or use suitable machines for removing the excess grout.
5. Cement-based grouts without additives: at the end of the day, clean off the grout residue with a slightly damp sponge. Unless otherwise indicated by the manufacturer, “after-laying” cleaning if the flooring should be carried out after 4-5 days (to allow the necessary hardening of the grout, in the joints), by first wetting the joints with water, then using suitable acid-based detergents. Do not wait too long before carrying out this cleaning: after two weeks it already becomes too laborious. Do not do “after-laying” cleaning if the temperature of the tiles is high: in summer, do it in the cool hours of the day.
6. Epoxy grouts and grouts containing additives (with latex etc.) follow the manufacturer’s instructions carefully, because the rapid hardening of these grouts can necessitate very laborious claning, especially if the tiles have a rough, anti-slip or structured surface.

## CLEANING-PROTECTION AND ROUTINE CARE OF PORCELAIN TILES

The first cleaning after the tiles installation will influence the cleanability of the surface for its entire life.

Floors and wall installations well planned and correctly layed represent very durable surfaces.

Common-sense precautions are nevertheless necessary, as well as a good technical knowledge of the materials.

## CLEANING AFTER LAYING

The cleaning after laying is an extremely important phase from which depends all the future applications and the maintenance of the floor.

With an acid base cleaning after the floor installation it is possible to remove the regular dirt that can be found on the jobsite: cement, glue, paint stains... It is worth to know that more than 90% of the claims is due to a not proper cleaning after laying with acid base detergent. Sometimes this phase is even missing.

Before cleaning an installed floor with an acid base product it is strongly suggested to pour water on the surface in order to wet the grout joint and protect them from the corrosive action of the acid. Otherwise it may happen that the acid solution included in the cleaning product could erode the grout.

In case the first cleaning is made after the floor has been used, it is necessary to remove the dirt that could be found on the floor using alkaline based product, and then proceed with the post laying cleaning. After this process it is necessary to profusely pour water on the floor and, as a final step, remove as much dirty water as possible.

The cleaning after laying needs to be done once the grout in the joint is fully dry (48 to 72 hours), properly following the indication of the manufacturer of the cleaning product used.

The cleaning after laying made with acid based products needs to be done only once and has the advantage of maintaining an uniformity in the colour tone of the entire floor.

## ROUTINE MAINTENANCE

You are recommended to use ordinary neutral detergent diluted in water. Avoid using acid or alkaline products, waxes and/or impregnants.

During ordinary cleaning it is recommended to use extremely abrasive items (such as scourers and iron or steel sponges) as little as possible.

This recommendation must be adhered to rigorously in the case of tiles with a glossy surface finishing as they are more susceptible to the risk of scuffs, scratches and loss of shine, etc.

In the event of heavy dirt or particularly textured surfaces, use an alkaline detergent and rinse after washing. For large surfaces, the use of a floor washing machine is recommended. During every-day cleaning procedures, it is necessary to remember that certain types of dirt (dust, sand) increase the abrasive effect of foot-traffic. Therefore we recommend that you avoid bringing in this type of dirt, which comes in from the outside, by placing a door-mat at the entrance.

## EXTRAORDINARY MAINTENANCE

In the event of dirt resistant to the ordinary cleaning, use a suitable detergent for that particular kind of dirt.

## METALLIZED FLOOR AND WALL TILES

For the cleaning and maintenance of the tiles with iridescent metal effect surface it is strictly recommended not to use acid or alkaline detergents.

Please use exclusively products with neutral PH.

In any case please test each cleaning product in advance, if possible on a piece of the material not laid and avoid to leave the detergent on the tiles for more than 10-15 minutes. Always rinse heavily with water after cleaning.

## RECOMMENDATIONS

Last but not least, please remember never to use stain remover such as anti-rust products or sprays, because they contain hydro-fluoric acid: this would cause irreparable damage since no floor tile in the world, whether produced by us or others, withstands this acid.

The following are the most suitable cleaning products for the various types of dirt.

## WARNING

The cleaning characteristics of the materials may vary significantly depending on the laying method, conditions of use, type of surface and environment.

Generally speaking, the higher the non-slip characteristics of the tiles, the more difficult they are to clean.

The maintenance and cleaning operator should always test each cleaning method empirically in advance (if possible on a piece of the material not laid).

In the case of particularly heavy use, incorrect laying or inappropriate cleaning, Serenissima declines all responsibility for the

effectiveness of cleaning and maintenance operations.

Serenissima can under no circumstances be held responsible for events, damage or defects caused by incorrect laying, negligent cleaning and maintenance or the use of inappropriate materials and adhesives.

The information within this paragraph are purely indicative. For more specific information please refer to the proper documentation available on the catalogues and websites of the main cleaning products manufacturers like for example Fila Industria Chimica spa (www.filachim.com), Mapei S.p.A. (www.mapei.it), Kerakoll S.p.A. (www.kerakollgroup.com), Bonasystems Italia S.r.l. (www.bonasystemitalia.it), Faber Chimica S.r.l. (www.faberchimica.com), Periscopio s.r.l. (www.periscopiosoluzioni.com).

## TREATMENT OF HONED AND POLISHED PRODUCTS

Polish and lap are process that foresee the removal and polishing of the superficial part of the glaze or of the tile body.

In all glazed floor tiles available in the market, this process, even with vitreous or with very low absorption materials, can involve the opening of superficial micro porosity which, in contact with particular kind of dirtiness, can be hard to clean or present haloes hardly removable.

Serenissima recommends, after the washing after the laying, that must be made using an acid cleaner, to effect an antistain protection with certified products, in order to prevent that the material can absorb the stains maintaining unchanged the aesthetic and technical features of glazed porcelain.

We remind you that any treatement the producer maker before laying, will be completely removed by washing at acid base that must be done after the laying and therefore no efficace anti stain can be granted.

To Serenissima's customer it is requested to inform, before the delivery, layers and/or consignees of our products with the advices, warnings and recommendations inside this book. Serenissima declines all responsibility for the lack of these information which can cause problems during or after the laying of the product.





# PRODOTTI PER LA PULIZIA E LA MANUTENZIONE

Installation and maintenance guidelines . Indications pour la pose et l'entretien . Hinweise zur verlegung und pflege

# PRODOTTI PER LA PULIZIA E LA MANUTENZIONE

Installation and maintenance guidelines . Indications pour la pose et l'entretien . Hinweise zur verlegung und pflege

## PRODOTTI PER LA PULIZIA E LA MANUTENZIONE (\*)

CLEANING AND MAINTENANCE PRODUCTS (\*) - PRODUITS DE NETTOYAGE ET D'ENTRETIEN (\*) - PRODUKTE ZUR REINIGUNG UND PFLEGE (\*)

Salvo diversa indicazione in tabella, per l'utilizzo dei detergenti in elenco seguire attentamente le indicazioni riportate sulle confezioni.

Unless otherwise indicated in the table, when using the detergents listed, follow the instructions on the pack carefully. Sauf mention contraire dan le tableau, pour l'utilisation de détergents repris dans la liste, suivre attentivement les recommandations d'usage figurant sur l'emballage du produit. Solange die Tabelle keine anderweitigen Angaben enthält, befolgen Sie bei der Verwendung von Reinigungsmitteln sorgfältig die Anweisungen auf den Verpackungen.

Tipo di sporco Type of dirt Type de salete Schmutzart	Tipo di detergente Type of detergent Type de detergent Art des reinigungsmittels	Nome detergenti Name of detergent Nom du detergent Name des reinigungsmittels	Produttore Manufacturer Fabricant Hersteller
<b>Cemento, calce, stucchi cementizi, ruggine</b> Cement, lime, cement-based grouts, rust Ciment, chaux, enduits de ciment, rouille Zement, Kalk, Zementspachtelmasse, Rost	<b>A base acida</b> Acid-based A base acide Auf Säurebasis	DETERDEK DELTA PLUS CEMENT KERANET XTREME GRES CLEANER BONA CLEAN	FILA KERAKOLL FABER CHIMICA MAPEI PERISCOPIO BONASYSTEM
<b>Stucco epossidico</b> Epoxy-based grouts Mastic epoxy résiduelle Reste von Epoxidfugenmaterial	<b>A base alcalina</b> Alkali-based A base alcaline Auf alkalischer Basis	FILA CR10 FUGALITE GRAFFITI REMOVER KERAPOXY XTREME EPOXY CLEANER BONA DECON	FILA KERAKOLL FABER CHIMICA MAPEI PERISCOPIO BONASYSTEM
<b>Vino, caffè, bibite, succhi di frutta</b> Wine, coffee, soft drinks, fruit juice Vin, café, boissons, jus de fruits Wein, Kaffee, Getränke, Fruchtsäfte	<b>Polifunzionali, a base alcalina</b> Multi-purpose, alkali-based Multifonction, à base alcaline Alkalische Allzweckreiniger	FILA PS87 COLOURED STAIN REMOVER XTREME ALCALINE BONA DECON	FILA FABER CHIMICA PERISCOPIO BONASYSTEM
<b>Pneumatici</b> Tyremarks Pneumatiques Reifenschmutz	<b>A base alcalina</b> Alkali-based A base alcaline Auf alkalischer Basis	FILA PS87 GRAFFITI REMOVER XTREME ALCALINE BONA DECON	FILA FABER CHIMICA PERISCOPIO BONASYSTEM
<b>Cere, grassi</b> Wax, fats Cires, graisses Wachs, Fett	<b>A base solvente</b> Solvent-based A base de solvant Auf Lösungsmittelbasis	FILA SOLV WAX REMOVER XTREME EPOXY CLEANER BONA DECON	FILA FABER CHIMICA PERISCOPIO BONASYSTEM
<b>Patine lasciate da detergenti</b> Residue left by detergents Patines laissées par des nettoyeurs Schleier aus Reinigungsmittelrückständen	<b>Polifunzionali, a base alcalina</b> Multi-purpose, alkali-based Multifonction, à base alcaline Alkalische Allzweckreiniger	FILA PS87 THE CLEANER XTREME ALCALINE BONA DECON	FILA FABER CHIMICA PERISCOPIO BONASYSTEM
<b>Segni di matita, segni metallici</b> Pencil marks, metallic marks Traces de crayon, traces métalliques Bleistift-und metallische Rückstände	<b>A base acida</b> Acid-based A base acide Auf Säurebasis	DETERDEK CEMENT REMOVER XTREME GRES CLEANER BONA CLEAN	FILA FABER CHIMICA PERISCOPIO BONASYSTEM
<b>Inchiostri, pennarello</b> Ink, marker pens Encres, marqueurs Tinte, Filzstift	<b>A base alcalina</b> Alkali-based A base alcaline Auf alkalischer Basis	FILA PS87 - FILA SR95 COLOURED STAIN REMOVER XTREME EPOXY CLEANER BONA DECON	FILA FABER CHIMICA PERISCOPIO BONASYSTEM
<b>Pulizie quotidiane</b> Everyday cleaning Nettoyage quotidien Tägliche Reinigung	<b>Neutro o alcalino</b> Neutral or alkaline Neutre ou alcalin Neutral-oder alkalische Reiniger	FILA CLEANER FLOOR CLEANER EVERY FLOOR BONAMAIN +	FILA FABER CHIMICA PERISCOPIO BONASYSTEM

(\*) Eseguire sempre test preventivo sulle piastrelle prima dell'uso, in particolare su prodotti lappati o levigati.

(\*) Always do a test in advance on the tiles before use, particularly on Lapper or Ground products.

(\*) Toujours procéder à un essai sur les carreaux avant l'utilisation, surtout pour les articles rodés ou polis.

(\*) Vor der Benutzung sollten Sie immer erst einen prophylaktischen Probeauftrag durchführen, besonders auf geläpften oder polierten Fliesen.

(\*) Рекомендуется всегда проводить предварительное испытание перед использованием, особенно на лапатированной или полированной плитке.

BONASYSTEMS Italia S.r.l.

Via Borgo S. Chiara, 29 - 30020 Torre di Mosto (VE) ITALY

Tel +39 0421 325691 - www.bonasytemsitalia.it

FABER CHIMICA S.r.l.

Via G. Ceresani, 10 - Località Campo d'Olmo - 60044 Fabriano (AN) - ITALY

Tel. +39 0732-627178 - www.faberchimica.com

FILA Industria Chimica S.p.A.

Via Garibaldi, 32 - 35018 San Martino di Lupari (Padova) - ITALY

Tel. 049.946.73.00 - www.filachim.com

PERISCOPIO s.r.l.

Sede legale. Via Rainusso n. 90 - 41124 Modena

Sede operativa. Via S.Maria 11 - 41013 Castelfranco Emilia (MO)

Tel. +39 335360913 - www.periscopiosoluzioni.com

KERAKOLL S.p.A.

Via dell'Artigianato 9 - 41049 Sassuolo (MO) - ITALY

Tel +39 0536 816 511 - www.kerakollgroup.com

MAPEI S.p.A.

Via Cafiero 22 - 20153 Milano - ITALY

Tel. +39 02-37673 - www.mapei.it

# CONDIZIONI GENERALI DI VENDITA

General terms of sale . Conditions generales de vente . Allgemeine verkaufsbedingungen

**1. NORMATIVA CONTRATTUALE** - Le presenti condizioni generali, salvo eventuali modificazioni o deroghe concordate per iscritto, disciplinano tutti i contratti di vendita tra noi e l'acquirente, quindi tanto il contratto concluso con l'accettazione del presente ordine che qualsiasi contratto futuro relativo alle forniture dei prodotti della nostra società ordinati con successive e distinte commissioni.
**2. FORNITURE** - Il prezzo qui specificato si intende al netto di spese di trasporto, IVA ed eventuali diritti di dogana; per merce resa franco ns. stabilimento.
**3. ORDINI** - Il Committente si obbliga a mantenere ferma la proposta d'ordine rilasciata a personale commerciale della ns. società. Ogni ordine trasmesso dai ns. Agenti è sempre raccolto "SALVO APPROVAZIONE DELLA CASA", per cui ci riserviamo di non accettare o modificare l'ordine stesso. Quanto sopra vale anche per eventuali cessioni gratuite per sala mostra. Prima di evadere gli ordini, l'azienda si riserva la facoltà di richiedere informazioni commerciali.
**4. CONSEGNE**- I termini di consegna non sono mai impegnativi; comunque, il mancato espletamento dell'ordine se confermato o il ritardo nella sua esecuzione escludono ogni ns. responsabilità da cause a noi imputabili, quali impedimenti o difficoltà nei trasporti, scioperi, serrate, impossibilità o anche soltanto difficoltà di tempestivo approvvigionamento delle materie prime. Il committente, quindi, non può in nessun caso chiedere la risoluzione del contratto o esigere indennizzi da eventuali danni diretti o indiretti per il ritardo nella consegna.
**5. SCELTE** - Il materiale verrà consegnato nelle scelte disponibili. Pertanto, le richieste di determinate percentuali di scelta verranno intese come semplici indicazioni e soddisfatte compatibilmente con le rese di produzione.
**6. TRASPORTO** - La merce viaggia a rischio e pericolo del Committente anche se resa franco destino e la ns. responsabilità cessa con la consegna al vettore, per tanto, i reclami per eventuali ammanchi o rotture dovranno essere rivolti esclusivamente a questi.
**7. PREZZI** - Ci riserviamo la facoltà di modificare i prezzi del presente listino con un preawiso di 30 (trenta) giorni.
**8. PAGAMENTI** - I pagamenti devono pervenire presso la ns. sede. L'accettazione da parte ns. di effetti o assegni emessi fuori piazza o comunque il convenuto pagamento a mezzo tratte non deroga tale condizione. Le fatture non contestate entro 8 (otto) giorni dal ricevimento si intendono accettate. I pagamenti dovranno avvenire nei modi e nei termini pattuiti nella ns. commissione. In caso di ritardato pagamento di somme a noi dovute, è ns. facoltà sospendere le forniture e annullare i rapporti in corso. Gli interessi per ritardato pagamento dovranno essere convenuti espressamente con tassi da definire. In difetto verranno applicati gli interessi moratori di legge.
**9. CONTESTAZIONE PER VIZI** - Eventuali contestazioni per vizi qualsiasi sia palesi sia occulti della merce oggetto della fornitura devono essere inoltrate alla ns. sede a mezzo raccomandata con avviso di ricevimento entro 8 (otto) giorni dal ricevimento della merce. In ogni caso, prima di procedere alla posa del materiale ceramico compravenduto sarà onere dell'acquirente e/o del cliente finale a cui tale obbligazione dovrà essere contrattualmente estesa, verificare la sussistenza o meno di vizi e/o difetti palesi e ciò al fine di non aggravare il danno. Eventuali reclami che dovessero riguardare il materiale già in opera verranno pertanto respinti. La posa in opera determinerà rinuncia alla garanzia per vizi palesi della merce fornita e comunque integrerà quanto disposto dall'art.1227 c.c... E' espressamente esclusa la garanzia per la merce classificata di seconda o terza scelta, blocchi o partite occasionali. Offerte, transazioni, accrediti concessi dai ns. Agenti o intermediari non sono validi se non confermati per iscritto dalla ns. sede. I nostri campioni sono soltanto indicativi e vengono da noi presentati al solo scopo di fornire al cliente indicazioni di massima del prodotto.
**10. SOLVE ET REPETE** - Nessuna eccezione, salvo quelle di nullità, annullabilità e rescissione del contratto, può essere opposta dall'acquirente al fine di ritardare od evitare il pagamento.
**11. RISERVATO DOMINIO** - La vendita della merce viene effettuata con la clausola del riservato dominio, sicché la proprietà della stessa passerà all'acquirente solo con l'integrale ed effettivo pagamento del prezzo. Il mancato pagamento anche di una sola rata produrrà lo scioglimento del contratto con la facoltà di esigere l'immediato pagamento di tutte le rate anche non scadute ovvero l'immediata restituzione della merce. In tal caso le somme versate resteranno acquisite al venditore a titolo di indennità.
**12. CLAUSOLA COMPROMISSORIA** - Ad eccezione delle controversie inerenti il pagamento del prezzo ed alle relative azioni esercitate in via monitoria o nel giudizio ordinario, che rimangono di competenza dell'autorità giurisdizionale italiana, qualunque altra controversia che dovesse insorgere in ordine alla conclusione e/o esecuzione e/o risoluzione e/o interpretazione del presente contratto sarà devoluta ad un collegio di tre arbitri, nominati uno da ciascuna delle parti, ed il terzo di comune accordo o, in caso di disaccordo, dal Presidente della C.C.I.A.A. di Reggio Emilia, a richiesta della parte più diligente. La parte che intende avviare l'arbitrato deve comunicarlo all'altra parte con lettera raccomandata contenente la nomina del proprio arbitro e la sua accettazione. L'altra parte dovrà nominare il proprio arbitro nel termine di 15 giorni dalla data di ricezione della raccomandata, comunicando tale nomina e la relativa accettazione entro il termine indicato. In difetto l'altra parte potrà richiedere la nomina del secondo arbitro al Presidente della C.C.I.A.A. di Reggio Emilia. Gli arbitri decideranno secondo diritto e nel rispetto del principio del contraddittorio; il loro dovrà essere deliberato nel termine di 90 giorni decorrenti dalla data di accettazione dell'ultimo arbitro. L'arbitrato avrà sede in Reggio Emilia.
**13. FORO COMPETENTE E LEGGE APPLICABILE** - Per qualsiasi controversia è esclusivamente competente il Foro di Reggio Emilia e la legge applicabile è esclusi vamente quella italiana.
**14. EFFETTIVITA' DI CIASCUNA CONDIZIONE** - Le condizioni generali di vendita sopra riportate non devono assolutamente intendersi come clausole di puro stile. Esse sono effettive e rappresentano fedelmente la volontà negoziale delle parti.
**15. RICEZIONE MERCE** - Alla ricezione della merce, il cliente è tenuto a verificare che il prodotto consegnato sia conforme a quanto dichiarato nel d.D.T. (Documento di trasporto). Non si accettano reclami per materiale consegnato in cantiere in difformità. Da quanto riportato nel documento stesso. Qualora fosse riscontrata difformità, il gruppo romani si assumerà. I costi di trasporto per l'eventuale sostituzione/integrazione della quantità di prodotto non conforme. Per ogni richiesta di reso dovuta ad errori di ordine, rinuncia da parte del cliente o comunque per motivi non imputabili all'azienda. Sarà richiesto un contributo pari al 10% del valore della merce resa.

**1. CONTRACTUAL REGULATIONS** – Subject to possible modifications or variations agreed in writing, these general conditions govern all sales contracts between us and the purchaser, and therefore both the contract entered into with acceptance of this order and any future contracts relating to supplies of our company's products ordered with subsequent and separate commissions.
**2. SUPPLIES** - The price set forth herein is understood as net of transport costs, VAT and any customs duties, for goods delivered ex works our factory.
**3. ORDERS** - The Principal undertakes to maintain as valid the order proposal issued to our company's sales personnel. Each order sent by our Agents is always accepted "SUBJECT TO COMPANY APPROVAL", and we therefore reserve the right not to accept or modify the order itself. The above also holds true for any free-of-charge transfers for the showroom. Before fulfilling orders, the company reserves the right to request sales information.
**4. DELIVERIES** - Delivery terms are never binding; in any event, we shall not be deemed responsible for any delivery or performance delays of orders, where confirmed, due to events attributable to us, such as obstacles or difficulties in transport, strikes, lockouts, impossibility or even only difficulty in prompt procurement of raw materials. The principal, therefore, cannot in any case request the termination of the contract or claim compensation for any direct or indirect damages due to delay in delivery.
**5. GRADES** - The material will be delivered in the grades available. Therefore, requests for certain percentages of grades will be understood as simple indications and fulfilled according to production outputs.
**6. TRANSPORT** - Goods travel at the Principal's own risk even if delivered carriage paid and our responsibility ceases with delivery to the carrier; therefore, com plaints about any shortfalls or breakages must therefore be made exclusively to the latter.
**7. PRICED** – We reserve the right to modify the prices in the price-list with 30 (thirty) days' advance notice.
**8. PAYMENTS** - Payments must be made to our head office. Our acceptance of bills or non-locally issued cheques or in any case agreed payment by banker's drafts does not create an exception to this condition. Invoices not contested within 8 (eight) days from receipt are understood as accepted. Payments must be made in the ways and under the terms agreed in our commission. In the case of late payment of sums owed to us, we have the right to suspend supplies and cancel the relationships in progress. Interest for late payment must be expressly agreed with rates to be defined. In the absence of this, legal default interest will be applied.
**9. CONTESTED DEFECTS** - Any contested defects of the goods that are the subject of the supply, whether apparent or hidden, must be forwarded to our head office by registered letter with return receipt within 8 (eight) days from receipt of the goods. In any case, before proceeding with laying the ceramic material pur chased, it will be the responsibility of the purchaser and/or of the end customer, to whom this obligation must be contractually extended, to check the existence of apparent faults and/or defects, in order not to worsen the damage. Any complaints concerning material already laid will therefore be rejected. Laying of the material will constitute waiver of warranty for apparent defects in the goods supplied and in any case will supplement the provisions of Article 1227 of the Italian Civil Code. Warranty for goods classified as second or third grade, occasional lots or batches is expressly excluded. Offers, transactions and credits granted by our Agents or intermediaries are not valid unless confirmed in writing by our head office. Our samples are only indicative and are presented by us for the sole purpose of providing the client with a general idea of the product.
**10. SOLVE ET REPETE** - No exception, save that of nullity, possibility of cancellation, and termination of the contract, can be claimed by the purchaser with the pur pose of delaying or avoiding payment.
**11. TITLE RETENTION** - Sale of the goods is carried out with the title retention clause, so that ownership of the same shall pass to the purchaser only with the complete and effective payment of the price. Failure to pay even one single instalment will cause termination of the contract with the right to demand immediate payment of all instalments even if not expired or the immediate return of the goods. In the latter case the seller shall retain the sums paid, by way of indemnity.
**12. ARBITRATION CLAUSE** - Except for disputes relating to payment of the price and the relative actions brought in summary proceedings or in the ordinary court, which fall under the competence of the Italian legal authorities, any other dispute that may arise concerning the conclusion and/or execution and/or termination and/or interpretation of this contract shall be transferred to a board of three arbitrators, one appointed by each of the two parties and the third by common agreement or, in the case of disagreement, by the Chairman of the Reggio Emilia Chamber of Commerce, Industry, Agriculture and Small Business (C.C.I.A.A.), by request of the most diligent party. The party which intends to start up the arbitration must notify this to the other party with a registered letter containing the appointment of its own arbitrator and his/her acceptance. The other party must appoint its own arbitrator within 15 days from the date of receipt of the registered letter, notifying this appointment and relative acceptance within the time-limit indicated. If this should not be done the other party may request the Chairman of the Reggio Emilia C.C.I.A.A. to appoint the second arbitrator. The arbitrators shall decide according to law and in observance of the adversarial nature of the proceedings; the award must be resolved on within a time-limit of 90 days starting from the date of acceptance of the last arbitrator. The arbitration will take place in Reggio Emilia.
**13. COURT OF JURISDICTION AND GOVERNING LAW** – For any dispute the Court of Reggio Emilia has exclusive jurisdiction and the governing law is exclusively Italian law.
**14. EFFECTIVENESS OF EACH CONDITION** - The above general conditions of sale must under no circumstances be understood merely as standard clauses. Theyare effective and faithfully represent the contractual intent of the parties.
**15. GOODS RECEIPT** - Upon receipt of the goods, the customer has to verify that the material is compliant to what declared in the transport document. Complaints for material that does not correspond to what declared in the transport document that has already been delivered to job site will not be accepted. Gruppo romani will be responsible for cost of transport and eventual replacement or supply of material that has been found to be not compliant to what declared in the transport document. For any request for goods to be returned due to order errors, refusal by the customer or in any case for reasons not attributable to the company, a contribution of 10% of the value of the goods returned will be required.

# CONDIZIONI GENERALI DI VENDITA

General terms of sale . Conditions generales de vente . Allgemeine verkaufsbedingungen

**1. DISPOSITIONS CONTRACTUELLES** - Sauf modifications ou dérogations éventuelles convenues par écrit, les présentes conditions générales régissent tous les contrats de vente entre nous et l'acheteur, autrement dit tant le contrat conclu lors de l'acceptation de la présente commande que tout contrat futur relatif à la fourniture de produits de notre société demandés à l'occasion de commandes successives et distinctes.
**2. FOURNITURES** - Le prix indiqué ici s'entend hors frais de transport, TVA et éventuels droits de douane, pour des marchandises départ usine.
**3. COMMANDES** - L'acheteur s'engage à ne pas se rétracter de la proposition de commande faite au personnel commercial de notre société. Les commandes sont toujours transmises par nos agents « SOUS RÉSERVE DE L'APPROBATION PAR NOTRE SOCIÉTÉ », avec la faculté d'accepter ou de modifier la commande. Les indications ci-dessus s'appliquent également en cas de cessions gratuites à des salles d'exposition. Avant de traiter les commandes, l'entreprise se réserve le droit de demander des informations commerciales.
**4. LIVRAISONS** - Les délais de livraison n'ont pas valeur contractuelle. L'exécution d'une commande déjà confirmée ou un retard de livraison excluent toute responsabilité de notre part en cas de causes qui nous seraient imputables, telles que des empêchements ou des difficultés de transport, des grèves, des lockout, des impossibilités ou même des difficultés d'approvisionnement en temps voulu en matières premières. L'acheteur ne peut donc en aucune façon demander la résiliation du contrat ou des indemnités du fait d'éventuels dommages directs ou indirects liés à un retard de livraison.
**5. CHOIX** - Le matériau livré sera prélevé parmi les différents choix de produits disponibles. Par conséquent, au cas où des pourcentages de choix de produits spécifiques seraient demandés, ceux-ci seront considérés comme de simples indications et satisfaits dans la limite des quantités produites.
**6. TRANSPORT** - La marchandise, même lorsqu'elle est fournie franco destination, voyage aux risques et périls de l'acheteur, notre responsabilité cessant au moment de la remise au transporteur. C'est pourquoi les réclamations pour d'éventuels matériaux manquants ou abîmés devront être adressées exclusivement à celui-ci.
**7. PRIX** - Nous nous réservons le droit de modifier les prix de la présente liste de prix avec un préavis de 30 (trente) jours.
**8. PAIEMENTS** - Les paiements doivent parvenir au siège de notre société. L'acceptation d'effets ou de chèques émis hors place ou le paiement, après accord préalable, moyennant plusieurs traites, n'invalide pas cette condition. Les factures n'ayant pas fait l'objet d'une réclamation dans les 8 (huit) jours après leur réception s'entendent acceptées. Les paiements devront être effectués selon les modalités et dans les délais convenus dans le contrat de fourniture. En cas de retard de paiement, notre société est en droit de suspendre les fournitures et d'annuler les contrats en cours. Les intérêts liés aux retards de paiement et leurs taux devront être expressément convenus. A défaut, les intérêts moratoires légaux s'appliqueront.
**9. RÉCLAMATIONS POUR VICES** - Les éventuelles réclamations pour vices apparents ou cachés de la marchandise faisant l'objet de la fourniture doivent être adressées à notre siège par lettre recommandée AR dans un délai maximum de 8 (huit) jours après réception de la marchandise. Quoi qu'il en soit, avant de procéder à la pose du matériau céramique vendu, il incombe à l'acheteur et/ou au client final, à qui cette obligation devra être contractuellement étendue, de vérifier l'existence ou non de vices et/ou de défauts apparents afin de ne pas aggraver le préjudice. Toute réclamation concernant le matériau déjà posé sera par conséquent rejetée. La pose du matériau entraîne le renoncement à la garantie pour vices apparents de la marchandise fournie et intègre les dispositions de l'art. 1227 du Code civil italien. La garantie est expressément exclue pour les deuxième ou troisième choix de marchandises, les blocs ou les lots occasionnels. Les offres spéciales, transactions, crédits consentis par nos agents ou intermédiaires n'ont aucune validité s'ils n'ont pas été confirmés par écrit par notre siège. Nos échantillons sont fournis à titre indicatif et ne sont présentés que dans le but de fournir au client des indications générales sur le produit.
**10. SOLVE ET REPETE** - L'acheteur ne peut se prévaloir d'aucune exception, sauf celles de nullité, d'annulation et de rupture du contrat, pour retarder ou éviter le paiement.
**11. RÉSERVE DE PROPRIÉTÉ** - La vente des marchandises inclut une clause de réserve de propriété, de sorte que les marchandises ne deviendront la propriété de l'acheteur qu'après le paiement intégral et effectif du prix. Le non-paiement ne serait-ce que d'une seule traite entraînera la résiliation du contrat, sans préju de ce du droit au paiement immédiat de toutes les traites, y compris celles qui ne seraient pas encore arrivées à échéance, ou la restitution immédiate de la mar chandise. Dans ce cas, les sommes versées seront acquises au vendeur à titre d'indemnités.
**12. CLAUSE COMPROMISSOIRE** - Exception faite des litiges inhérents au paiement du prix et aux actions correspondantes exercées à titre d'avertissement et dans le jugement ordinaire, qui restent de la compétence de l'autorité juridictionnelle italienne, tout autre litige en lien avec la conclusion et/ou l'exécution et/ou la résolution et/ou l'interprétation du présent contrat sera soumis à un collège arbitral composé de trois membres, chaque partie en nommant un et le dernier étant nommé d'un commun accord ou, dans l'éventualité d'un désaccord, par le Président de la C.C.I.A.A. de Reggio Emilia à la demande de la partie la plus diligente. La partie souhaitant demander un arbitrage doit en informer l'autre par une lettre recommandée indiquant l'arbitre nommé et l'acceptation par celui-ci. L'autre partie devra nommer un arbitre dans un délai de 15 jours à compter de la date de réception de la lettre recommandée, en communiquant cette nomination et son acceptation dans le délai indiqué. À défaut, l'autre partie pourra demander au Président de la C.C.I.A.A. de Reggio Emilia de procéder à la nomination du deuxième arbitre. Les arbitres baseront leur décision sur les dispositions réglementaires, dans le respect du principe du contradictoire. La sentence devra être émise dans un délai de 90 jours à compter de la date d'acceptation par le dernier arbitre. L'arbitrage aura lieu à Reggio Emilia.
**13. TRIBUNAL COMPÉTENT ET LÉGISLATION APPLICABLE** - En cas de litige, le Tribunal de Reggio Emilia sera seul compétent et la législation italienne sera la seule à s'appliquer.
**14. EFFECTIVITÉ DE CHAQUE CONDITION** - Les conditions générales de vente indiquées ci-dessus ne doivent en aucune façon être considérées comme des clau ses de style. Elles sont effectives et représentent fidèlement la volonté commerciale des parties.
**15. RECEPTION DES MARCHANDISES** - Au moment de réception de la marchandise, le client doit contrôler que le produit reçu soit conforme à ce qu'il y a marqué dans le Bulletin de livraison. L'usine n'acceptera pas de réclamation pour du matériel livré sur le chantier qui n'est pas conforme à ce qu'il y a écrit dans le bulletin de livraison. Lorsqu'il y aura le constat de marchandise non conforme, gruppo romani prendra charge des frais de transport pour l'éventuel remplacement et/ou intégration de la quantité de produit non conforme. Pour toute demande de retour en raison d'erreurs de commande, de renociation de la part du client ou pour toute autre raison non imputable à la société, une contribution de 10 % de la valeur de la marchandise retournée sera demandée au client.

**1. VERTRAGSBEDINGUNGEN** - Diese allgemeinen Bedingungen regeln mit Ausnahme eventuell schriftlich vereinbarter Änderungen oder Abweichungen alle Verkaufsverträge zwischen uns und dem Käufer, d.h. sowohl den abgeschlossenen Vertrag mit der Annahme der vorliegenden Bestellung, als auch jeden zukünftigen Vertrag, der sich auf die Lieferungen von Produkten unserer Gesellschaft bezieht, die an späteren Zeitpunkten mit gesonderten Aufträgen bestellt werden.
**2. LIEFERUNGEN** - Der hier aufgeführte Preis ist der Nettopreis ohne Transportkosten, Mehrwertsteuer und eventuelle Zollgebühren und gilt für Warenübergabe bei unserem Produktionswerk.
**3. BESTELLUNGEN** - Der Auftraggeber verpflichtet sich, die Gültigkeit seines an das Vertriebspersonal unserer Gesellschaft erteilten Bestellvorschlages aufrecht zu erhalten. Jede von unseren Vertretern zugesandte Bestellungen wird immer „VORBEHALTLICH UNSERER ZUSTIMMUNG“ entgegengenommen, d.h. wir behalten uns vor, die Bestellung nicht anzunehmen oder sie zu ändern. Dies gilt auch für eventuelle kostenlose Äbtrungen für Ausstellungsräume. Vor der Erledigung der Bestellungen behalten wir uns vor, geschäftliche Informationen einzuholen.
**4. LIEFERUNGEN** - Die Liefertermine sind nie verbindlich; die Nichterledigung einer bestätigten Bestellung oder ihre verspätete Ausführung schließt in jedem Fall unsere Verantwortung wegen auf uns zurückzuführende Ursachen, wie Verhinderung oder Schwierigkeiten bei Transporten, Streiks, Arbeiterspannungen, nicht mögliche Beschaffung oder auch nur Schwierigkeiten bei der rechtzeitigen Beschaffung der Rohmaterialien, vollkommen aus.
**5. SORTIERUNG** - Das Material wird in den verfügbaren Sorten geliefert. Forderungen bestimmter Sortenanteile werden als einfache Hinweise entgegen genommen und je nach den Produktionsergebnissen erfüllt.
**6. TRANSPORT** - Die Waren werden auf Risiko und Gefahr des Auftraggebers versichert, auch wenn sie frei Haus verkauft werden, und unsere Verantwortung endet bei der Übergabe an den Frachtführer. Deshalb sind Reklamationen für eventuelle Fehlgangen oder Brüche ausschließlich an die Frachtführer zu richten.
**7. PREISE** - Wir behalten uns das Recht vor, die Preise dieser Preisliste mit einem Vorbescheid von 30 (dreißig) Tagen zu ändern.
**8. ZAHLUNGEN** - Die Zahlungen müssen bei unserer Niederlassung eingehen. Unsere Entgegennahme auswärtig ausgestellter Wertpapiere oder Schecks bzw. sonst vereinbarte Bezahlungen mittels Tratte sind keine Abweichungen von dieser Bedingung. Rechnungen, die nicht innerhalb von 8 (acht) Tagen ab Empfang beanstandet werden, gelten als akzeptiert. Die Zahlungen müssen in der Art und Weise und an den Falligkeiten erfolgen, die in unseren Aufträgen angegeben sind. Bei verspäteter Bezahlung uns schuldiger Beträge sind wir berechtigt, die Lieferungen einzustellen und die laufenden Geschäftsbeziehungen abzubrechen. Der Prozentwert der Verzugsverzugszinsen ist ausdrücklich zu vereinbaren. Andernfalls werden die gesetzlichen Verzugszinsen berechnet.
**9. MÄNGELANZEIGE** - Eventuelle Beanstandungen aufgrund irgendwelcher sowohl erkennbarer als auch verborgener Fehler an den zum Lieferumfang gehörenden Waren sind per Einschreibebrief mit Empfangsbescheinigung innerhalb von 8 (acht) Tagen ab Wareneingang an unsere Niederlassung zu senden. Der Käufer und/ der Endkunde ist in jedem Fall in die vertragliche Verpflichtung einzubinden, das erworbene keramische Material vor der Verlegung auf ggf. vorhandene er kennbare Fehler und/oder Mängel zu prüfen, um den Schaden nicht zu verschlimmern. Eventuelle Reklamationen für bereits verlegtes Material werden daher zurückgewiesen. Die Verlegung führt zum Verzicht auf die Garantie für erkennbare Fehler der gelieferten Waren und integriert in jedem Fall die Bestimmungen im Art. 1227 des ital. ZGB. Für Waren der zweiten und dritten Sorte, sowie für Blocklieferungen oder Sonderpartien ist die Garantie ausdrücklich ausgeschlossen. Angebote, Transaktionen und Vergütungen, die von unseren Vertretern oder von Vermittlern erteilt werden, sind nicht gültig, wenn sie nicht schriftlich von unserer Niederlassung bestätigt werden. Unsere Muster gelten nur richtungweisend und werden von uns nur vorgelegt, um den Kunden generelle Produktangaben zu liefern.
**10. KLAUSEL „SOLVE ET REPETE“** - Keine Einwände, ausgenommen die Nichtigkeit, Annullierbarkeit und Rückgängigmachung des Vertrags, können vom Käufer erhoben werden, um die Zahlung zu verzögern oder zu vermeiden.
**11. EIGENTUMSVORBEHALT** - Der Warenverkauf erfolgt mit der Eigentumsvorbehaltsklausel, d.h. das Eigentum der Waren geht erst auf den Käufer über, nachdem der Preis vollständig und effektiv bezahlt wurde. Die Nichtbezahlung auch nur einer Rate führt zur Vertragsauflösung mit Berechtigung zur Forderung der sofortigen Bezahlung aller auch noch nicht fälligen Raten oder der sofortigen Rückerstattung der Waren. In diesem Fall werden die bezahlten Beträge vom Verkäufer als Entschädigung einbehalten.
**12. SCHIEDSKLAUSEL** - Mit Ausnahme der Streitigkeiten in Bezug auf die Zahlung des Preises und der entsprechend getroffenen Maßnahmen zur Mahrung oderim ordentlichen Verfahren, für welche die italienische Gerichtsbehörde zuständig ist, wird jede sonstige Streitigkeit, die sich aus dem Abschluss und/oder aus der Ausführung und/oder Auflösung und/oder Auslegung des vorliegenden Vertrages ergeben sollte, einem Schiedskollegium mit drei Schiedsrichtern anvertraut, von denen zwei von jeweils einer der Parteien ernannt werden und der dritte Schiedsrichter in beiderseitigem Einverständnis, oder bei Uneinigkeit vom Vorsitzenden der Handels-, Industrie-, Handwerks- und Landwirtschaftskammer in Reggio Emilia nach Beantragung durch die sorgfältigere Partei. Die Par,te, die das Schiedsgericht einzuschalten beabsichtigt, muss die andere Partei per Einschreibebrief davon in Kenntnis setzen und darin den von ihr ernannten Schiedsrichter und dessen Annahmeerklärung bekannt geben. Die andere Partei muss ihren Schiedsrichter innerhalb von 15 Tagen ab Empfang des Einschreibebriefes ernennen und diese Ernennung mit dazugehöriger Annahmeerklärung innerhalb der angegebenen Frist mitteilen. Andernfalls kann die andere Partei die Ernennung des zweiten Schiedsrichters beim Vorsitzenden der Handels-, Industrie-, Handwerks- und Landwirtschaftskammer in Reggio Emilia beantragen. Die Schiedsrichter entscheiden laut Gesetz und unter Einhaltung des Verhandlungsgrundsatzes; der Schiedsspruch ist innerhalb von 90 Tagen ab dem Datum der Annahmeerklärung des letzten Schiedsrichters zu beschließen. Der Sitz des Schiedsgerichts wird in Reggio Emilia sein.
**13. GERICHTSSTAND UND ANWENDBARES RECHT** - Für alle Streitigkeiten ist ausschließlich der Gerichtsstand Reggio Emilia zuständig und allein das italienische Recht ist anwendbar.
**14. WIRKSAMKEIT JEDER BEDINGUNG** - Die oben aufgeführten allgemeinen Verkaufsbedingungen dürfen keinesfalls als reine Stilklauseln betrachtet werden. Sie sind wirksam und entsprechen getreu dem rechtsgeschäftlichen Willen der Parteien.
**15. WARENEMPFANG** - Nach erhält der ware verpflichtet sich der kunde, die gelieferte ware zu kontrollieren, insbesondere die übereinstimmung mit den daten des liefererscheins. Für auf die baustelle gelieferten material, das die angaben des liefererscheins nicht entspricht wird keine reklamation akzeptiert. Wenn die gelieferte ware die daten des liefererscheins nicht entspricht wird gruppno romani das material austauschen bzw. Ersetzen und die transportkosten bis zu dem kunden tragen. Für jede forderung auf rückerstattung auf grund von bestellungsfehlern, verzicht durch den kunden oder aus nicht dem unternehmen abzuschreibenden gründen, wird eine kostenbeteiligung von 10% des werts der rückerstatteten ware verlangt.

# NOTE TECNICHE SUI PALLET

Pallet technical notes . Notes techniques concernant les palettes . Technische hinweise zu den paletten

CAVALLETTO (DA 2 A 12 PEZZI)	
	<b>CAVALLETTO 120x120/100x100 cm € 35,00</b> Profondità 60 cm Larghezza 125 cm Altezza 145 cm
	<b>CAVALLETTO 80x180 cm € 35,00</b> Profondità 60 cm Larghezza 185 cm Altezza 105 cm
PALLET PARIETALI 120x120 cm > 12 PEZZI	
	<b>PALLET PARIETALI 120x120 cm € 35,00</b> Profondità 122 cm Larghezza 143 cm Altezza 56 cm
PALLET PARIETALI 100x100 cm > 12 PEZZI	
	<b>PALLET PARIETALI 100x100 cm € 35,00</b> Profondità 120 cm Larghezza 102 cm Altezza 53 cm
PALLET PARIETALI 20x180-26x180-80x180 cm > 12 PEZZI	
	<b>PALLET PARIETALI 20x180-26x180-80x180 cm € 35,00</b> Profondità 184 cm Larghezza 100 cm Altezza 46 cm

# BOOK2020

collections

## LISTINO PREZZI

PRICE LIST | TARIF | PREISLISTE | ПРАЙС-ЛИСТ

NEI FORMATI 26,5x180, 120x120 CM, 100x100 E 80x180, PER ORDINI INFERIORI AL PALLET COMPLETO, VERRÀ APPLICATO UN COSTO PALLET.  
FOR SIZES 26,5x180 CM, 120x120 CM, 100x100 CM AND 80x180 CM, AN EXTRA PALLET COST WILL BE APPLIED TO ORDERS THAT ARE LESS THAN A FULL PALLET QUANTITY.  
SUR LES COMMANDES INFÉRIEURES À LA PALETTE POUR LES FORMATS 26,5x180 CM, 120x120 CM, 100x100 CM ET 80x180 CM, NOUS RAJOUTERONS EN BAS DE FACTURE UN COÛT DE PALETTE  
POUR LES FRAIS D'EMBALLAGE.  
BEIM FORMAT 26,5x180 CM, 120x120 CM, 100x100 CM UND 80x180 CM FÜR BESTELLUNGEN UNTER DER VOLLEN PALETTEN WERDEN VERPACKUNGSKOSTEN BERECHNET.

**SERENISSIMA**

www.serenissima.re.it

Fasce di prezzo Price ranges Grupes des prix Preisgruppen	1° Scelta Mq 1st Choice Sqm 1 Choix Mc 1 Wahl Qm	1° Scelta Mq Paletta Frazionata
A1	€ 42,00	€ 45,00
A2	€ 44,00	€ 47,00
A3	€ 45,00	€ 49,00
A4	€ 46,00	€ 51,00
A5	€ 47,00	€ 52,00
A6	€ 48,00	€ 53,00
A7	€ 49,00	€ 54,00
A8	€ 50,00	€ 55,00
A9	€ 51,00	€ 56,00
A10	€ 52,00	€ 57,00
A11	€ 53,00	€ 58,00
A12	€ 54,00	€ 59,00
A13	€ 55,00	€ 60,00
A14	€ 56,00	€ 61,00
A15	€ 57,00	€ 63,00
A16	€ 58,00	€ 64,00
A17	€ 59,00	€ 65,00
A18	€ 60,00	€ 66,00
A19	€ 61,00	€ 67,00
A20	€ 62,00	€ 68,00
A21	€ 63,00	€ 69,00
A22	€ 64,00	€ 71,00
A23	€ 66,00	€ 73,00
A24	€ 67,00	€ 74,00
A25	€ 68,00	€ 75,00
A26	€ 69,00	€ 76,00
A27	€ 70,00	€ 77,00
A28	€ 71,00	€ 78,00
A29	€ 72,00	€ 79,00
A30	€ 73,00	€ 80,00
A31	€ 74,00	€ 81,00
A32	€ 75,00	€ 82,00
A33	€ 76,00	€ 83,00
A34	€ 77,00	€ 84,00
A35	€ 78,00	€ 85,00
A36	€ 80,00	€ 87,00
A37	€ 82,00	€ 89,00
A38	€ 83,00	€ 90,00
A39	€ 84,00	€ 91,00
A40	€ 85,00	€ 92,00
A41	€ 86,00	€ 93,00
A42	€ 87,00	€ 94,00
A43	€ 88,00	€ 95,00
A44	€ 89,00	€ 96,00
A45	€ 90,00	€ 97,00
A46	€ 94,00	€ 101,00
A46E	€ 99,00	€ 106,00
A47	€ 102,00	€ 110,00
A48	€ 107,00	€ 115,00
A49	€ 110,00	€ 120,00
A50	€ 124,00	€ 134,00
A51	€ 130,00	€ 140,00
A52	€ 132,00	€ 142,00
A53	€ 140,00	€ 151,00
A54	€ 160,00	€ 172,00
A55	€ 180,00	€ 193,00
A56	€ 190,00	€ 203,00
A57	€ 195,00	€ 208,00
A58	€ 200,00	€ 214,00
A59	€ 210,00	€ 225,00
A60	€ 220,00	€ 235,00
A61	€ 230,00	€ 246,00
A62	€ 240,00	€ 257,00
A63	€ 250,00	€ 267,00
A63A	€ 260,00	€ 278,00
A64	€ 290,00	€ 310,00
A65	€ 300,00	€ 321,00
A66	€ 310,00	€ 332,00
A67	€ 320,00	€ 342,00
A67A	€ 330,00	€ 353,00
A67B	€ 340,00	€ 363,00
A68	€ 350,00	€ 374,00
A69	€ 410,00	€ 439,00

Fasce di prezzo Price ranges Grupes des prix Preisgruppen	1° Scelta Pz 1st Choice Piece 1 Choix Unite 1 Wahl Stück
B1	€ 1,00
B2	€ 3,00
B3	€ 4,00
B4	€ 6,00
B5	€ 7,00
B6	€ 8,00
B7	€ 9,00
B8	€ 10,00
B9	€ 11,00
B10	€ 12,00
B11	€ 13,00
B12	€ 14,00
B13	€ 15,00
B14	€ 16,00
B15	€ 17,00
B16	€ 18,00
B17	€ 19,00
B18	€ 20,00
B19	€ 21,00
B20	€ 22,00
B21	€ 23,00
B22	€ 24,00
B23	€ 25,00
B24	€ 26,00
B25	€ 27,00
B26	€ 28,00
B27	€ 30,00
B28	€ 32,00
B29	€ 33,00
B30	€ 34,00
B31	€ 35,00
B32	€ 36,00
B33	€ 39,00
B34	€ 40,00
B35	€ 43,00
B36	€ 48,00
B37	€ 52,00
B38	€ 55,00
B39	€ 56,00
B40	€ 58,00
B41	€ 66,00
B42	€ 70,00
B43	€ 74,00
B44	€ 75,00
B45	€ 78,00
B46	€ 80,00
B47	€ 85,00
B48	€ 86,00
B49	€ 88,00
B50	€ 90,00
B51	€ 94,00
B52	€ 96,00
B53	€ 103,00
B54	€ 105,00
B55	€ 107,00
B56	€ 120,00
B57	€ 124,00
B58	€ 130,00
B59	€ 132,00
B60	€ 135,00
B61	€ 145,00
B62	€ 150,00
B62C	€ 180,00
B62D	€ 190,00
B63	€ 200,00
B63B	€ 220,00
B63C	€ 230,00
B63D	€ 240,00
B64	€ 280,00
B65	€ 300,00
B66	€ 340,00
B67	€ 380,00
B68	€ 400,00
B69	€ 450,00
B70	€ 480,00

Fasce di prezzo Price ranges Grupes des prix Preisgruppen	1° Scelta ml 1st Choice linear metre 1er choix ml 1. Wahl Lfm.
C1	€ 8,00
C2	€ 10,00
C3	€ 14,00
C4	€ 15,00
C5	€ 16,00
C6	€ 17,00
C7	€ 18,00
C8	€ 19,00



**Prezzo al m<sup>2</sup>**

Price x sqm  
Prix / m<sup>2</sup>  
Preis x qm

**Цена за квадратный метр**



**Prezzo al pezzo**

Price per piece  
Prix a l'unité  
Preis pro Stück

**Цена за штуку**



**Prezzo al m lineare**

Price per linear metre  
Prix au m linéaire  
1. Wahl Lfm.

**Цена за погонный м**

**\***

**IL PREZZO DELLA SCELTA COMMERCIALE, SE DISPONIBILE, È DEL -50% DAL PREZZO DELLA 1° SCELTA PALETTE COMPLETE**

**FOR COMMERCIAL GRADE TILES, IF AVAILABLE, A DISCOUNT OF 50% ON THE PRICE OF THE 1ST CHOICE TILES IN WHOLE PALLET IS APPLIED**

**LE PRIX DU CHOIX COMMERCIAL, SI DISPONIBLE, EST DE -50 % PAR RAPPORT AU PRIX DU 1ER CHOIX PALETTE COMPLETE**

**DER PREIS FÜR DIE HANDELSORTIERUNG BETRÄGT, WENN VERFÜGBAR, 50 % WENIGER ALS DER PREIS FÜR DIE 1. WAHL.**

TUTTI I DECORI E I BATTISCOPA SONO VENDUTI A SCATOLE INTERE.  
ALL DECORS AND BASEBOARDS ARE SOLD IN FULL BOXES.  
TOUS LES DECORS ET LES PLINTHES SONT VENDUS PAR BOÎTES COMPLÈTES.  
FORMTEILVERKAUF NUR KARTONSWEISE MÖGLICH.



IVA E TRASPORTO ESCLUSI, PALLET FAO € 8,00, MINI PALLET FAO € 4,70  
VAT AND TRANSPORT NOT INCLUDED, PALLET FAO € 8,00, MINI PALLET FAO € 4,70  
TVA ET TRANSPORT NON INCLUS, PALLET FAO € 8,00, MINI PALLET FAO € 4,70  
MWST UND TRANSPORT NICHT INBEGRIFFEN, PALLET FAO € 8,00, MINI PALLET FAO € 4,70

**Tutti i formati sono nominali.  
Consigli di posa e pulizia sul sito web, [www.serenissima.re.it](http://www.serenissima.re.it)**

All sizes are nominal.  
Laying and cleaning suggestion on website [www.serenissima.re.it](http://www.serenissima.re.it)  
Tous les formats sont nominaux.  
Conseils de pose et de nettoyage sur le site [www.serenissima.re.it](http://www.serenissima.re.it)  
Alle Formate sind Nennwerte.  
Verlege und reinigungshinweise auf der webseite [www.serenissima.re.it](http://www.serenissima.re.it)

**Serenissima si riserva la facoltà di modificare in qualunque momento le informazioni e le caratteristiche illustrate nel presente catalogo, che non sono comunque da ritenere legalmente vincolanti. I colori e le caratteristiche estetiche dei prodotti sono quanto più possibile vicini a quelli reali, nei limiti consentiti dai processi di stampa. Pesì e misure possono subire variazioni tipiche del particolare processo di cottura del materiale ceramico.**

Serenissima reserves the right to modify the information and the characteristics illustrated in this catalogue (which are in any case not legally binding) at any moment.  
The colours and appearance features of the products are as close as possible to reality, within the limitation of the printing process. Weights and dimensions are subject to the normal variations resulting from the ceramic firing process.

Serenissima se réserve la faculté de modifier à tout moments les informations et les caractéristiques figurant dans le présent catalogue, lesquelles niengagent pas par le fabricant au plan légal.  
Les couleurs et les caractéristiques esthétiques sont fidèles aux couleurs et caractéristiques réelles dans les limites des procédés dimpression. Le poids et les dimensions peuvent subir des variations, dues au processus de cuisson particulier du matériau céramique.

Die Firma Serenissima behält sich vor, die in diesem Katalog enthaltenen Informationen und Eigenschaften jederzeit zu ändern; sie gelten auf keinen Fall als gesetzlich bindend. Die Farben und ästhetischen Eigenschaften der Produkte kommen innrhalb der Möglichkeiten der Druckverfahren den tatsächlichen Eigenschaften so weit wie möglich nahe.  
Gewichte und abmessungen können infolge des besonderen brennverfahrens des keramikmaterials ändern.

**© Copyright 2020 Gruppo Romani S.p.A. Industrie Ceramiche: tutti i diritti riservati.  
Ogni riproduzione totale o parziale dei contenuti di questo catalogo, sia di testo sia di immagine, è vietata e sarà perseguita a termini di legge.**

© Copyright 2020 Gruppo Romani S.p.A. Industrie Ceramiche: all rights reserved.  
Total or partial reproduction of text or illustration of this catalogue is prohibited and is subject to legal sanction.

© Copyright 2020 Gruppo Romani S.p.A. Industrie Ceramiche: tous droits réservés.  
Toute reproduction totale ou partielle du contenu - textes et images - du présent catalogue est interdite et constituerait une contrefaçon sanctionnée par la loi.

© Copyright 2020 Gruppo Romani S.p.A. Industrie Ceramiche: alle Rechte vorbehalten.  
Der vollständige oder auszugsweise Nachdruck des Inhalts dieses Katalog in Schrift und Bild ist verboten und wird nach Maßgabe des Gesetzes geahndet.



© Copyright 2020 Gruppo Romani S.p.A. Industrie Ceramiche

Gruppo Romani S.p.A. Industrie Ceramiche  
[www.grupporomanispa.com](http://www.grupporomanispa.com)



**SERENISSIMA** 

DAL1968 | **SERENISSIMA CERAMICHE**

[www.serenissima.re.it](http://www.serenissima.re.it)

Via A. Volta 23/25 - 42013 Casalgrande (RE) Italy

Tel. +39 0522 998411/911

Fax Italy +39 0522 998910

Fax Export +39 0522 996218